



**Thermal Mass Flow Meter**



# **MODEL 3760 Series**

**Instruction Manual**

**KOFLOC Corp.**

## 《Prior to Use》 and 《Precautions for Safe Use》

Various visual signs are contained in this manual and attached to the product to ensure correct handling of the product and to prevent possible personal injury and property damage. Their meanings are as follows.

 <b><i>DANGER</i></b>	Ignoring this sign and handling the product incorrectly will immediately result in death or serious injury.
 <b>WARNING</b>	Ignoring this sign and handling the product incorrectly may result in death or serious injury.
 <b><i>CAUTION</i></b>	Ignoring this sign and handling the product incorrectly may result in personal injury or damage to property.

### ***Product warranty***

The contents of warranty

① Warranty period

The warrant period shall be one year after the shipment.

② Warranty range

If a malfunction of the product you purchased occurs because of our responsible reasons, offer of substitute or it will be charge-free repaired in our factory. But if a malfunction of the machine occurs due to the following reasons, even within the warrant period, it becomes the outside for a warranty.

- (a) Malfunctions due to erroneous applications, repairs or remodeling.  
(Including the case in which the manufacturing specification differs from the application conditions.)
- (b) Malfunctions due to the falling after the purchase.
- (c) Malfunctions caused by natural disasters such as fire, earthquake, water disaster and lightning stoke, or riots or wars.
- (d) Malfunctions caused by mixing-in of foreign matters out of the piping.
- (e) Malfunctions caused by the peculiar problems due to combinations with other built in equipment.

In addition, a warranty here means the warranty of the product simple substance of our company. So the damage induced by failure of the products of our company shall be eliminated from the object of warranty.

## Contents

1. Precautions for Handling
  - 1-1 Checking the ID Plate
  - 1-2 Precautions for Transportation
  - 1-3 Precautions for Product Storage
  
2. Overview
  - 2-1 Principle of Operation
  - 2-2 Standard Specifications
  - 2-3 Outline
  
3. Configuration
  - 3-1 Configuration of the Thermal Mass Flow Meter
  - 3-2 Precautions
  
4. Installation
  - 4-1 Installation Site
  - 4-2 Contamination of the Piping System
  - 4-3 Installation Posture
  - 4-4 Installation Method
  - 4-5 Wiring
  
5. Operation
  - 5-1 Warming Up
  - 5-2 Zero/Span Calibration
  - 5-3 Run
  - 5-4 Precautions for Use
  - 5-5 Gases Not Listed in Specifications (Conversion Factor)
  
6. Troubleshooting
  - 6-1 No Output
  - 6-2 Unstable Flow Rate Indication
  - 6-3 Significantly Different Flow Rate Indication
  - 6-4 Significantly Different Zero
  
7. Maintenance
  - 7-1 Zero/Span Calibration
  - 7-2 Cleaning the Inlet and Outlet Joints

## 1. Precautions for Handling

### 【1-1 Checking the ID Plate】

The ordered products have been assembled and adjusted one by one according to the specifications.

The ID plate attached to the back of the case shows the gases to use, flow rate and other specifications. Check to see if they comply with your order specifications.

Check items

① Model

② Flow rate

SCCM = ml/min at 0°C : 1 atm (101.3 kPa)

SLM = l/min at 0°C : 1 atm (101.3 kPa)

NCCM = ml/min at 20°C : 1 atm (101.3 kPa)

NLM = l/min at 20°C : 1 atm (101.3 kPa)

The unit of the flow rate is basically based on 0°C and 1 atm. To satisfy the request for the unit to be based on 20°C and 1 atm, the calibration temperature and atmospheric pressure will be added to the flow rate unit.

Example: SLM( 0°C, 1 atm) · · · · · Reference state at 0°C and 1 atm.

SLM(20°C, 1 atm) · · · · · Reference state at 20°C and 1 atm.

③ Fluid name

④ Marking of the serial No.

### 【1-2 Precautions for Transportation】

To prevent damage during transportation, it is requested that the product be moved to the installation site in the style as it has been received from KOFLOC.

### 【1-3 Precautions for Product Storage】

If the product will not be put in operation for a long period of time after it arrived at your site, failures may develop for unexpected reason.

If it is known that the product will not be used for a long period of time, take the following precautions:

- 1) Keep the product in the packing in which the product was received.
- 2) Select a place to store the product that satisfies the following requirements:
  - ① A place protected against rain and water.
  - ② A place free of vibration and impact.
  - ③ A place where the product can be kept at normal temperature and humidity (about 25°C and 65%).
  - ④ A place free of dust.
  - ⑤ A place free of corrosive gases.
  - ⑥ A place free of strong electric or magnetic field.
- 3) To store the product that has been used, purge it with clean air or N<sub>2</sub> to ensure that the measuring gas will not remain in the flow meter.

Protect the inlet and outlet of the measuring gas with caps to prevent intrusion of dust.

## 2. Overview

Model3760 series are electric mass flow meter. It can use as a mass flow rate measurement instrument of various gases.

### 【2-1 Principle of Operation】

The flow detect sensor is wound by heating wires on the outside of the metallic capillary in two places. When gas flows to this capillary, the heat of the heating wire in the upstream is removed by the gas and its temperature drops. The heat in the upstream is conducted to the downstream to cause a difference in the resistance values of these heating wires.

The difference in temperature in these two places is proportional to the flow rate of the gas. This temperature difference is used to calculate a flow rate, which is converted to an electric signal.

When a bypass capillary to bypass the flow to the sensor pipe is incorporated, the gas flow to the sensor is restricted to enable the equipment to be used for a wide range of flow rates.

The detected flow rates are output as electric signals from 0 to 5 VDC.

Note 1: Do not use the product in such a way as to take measurements at a flow rate above the full scale or perform control using such measured values. A flow of an excessive amount of gas may cause **saturation and reversal** of the output values to disable accurate flow rate measurement.

**\* About saturation and reversal:** If an amount of gas exceeding the full scale flows to the MFS, the given heat quantity of the sensor heater will be exceeded at a certain point of the flow rate due to the characteristics of the thermal sensor, which will cause the saturation and then reversal phenomena.

### 【2-2 Standard Specifications】

MODEL	3760	3765
Flow range( N <sub>2</sub> converted)	10SCCM—20SLM	30SLM—100SLM
Response	2sec. or less	3sec. or less
Accuracy	±1.0%F.S. (25°C)	±1.5 %F.S. (25°C)
Reproducibility	±0.5 %F.S.	
Pressure resistance	980kPa	
Working ambient temperature	5 – 45°C (Performance guaranteed at 15°C—35°C 0.2%F.S. / °C)	
Material in contact with gas	SUS316,SUS316L, Teflon, FKM	
Flow rate output signal	0 – 5 VDC	
Drive power supply	DC±15V(±5%)100mA	
Connector	Dsub9pin (male)	

Please ask separately about details and specification.

Note: F.S.: Full-scale flow rate

**【2-3 Outline】**

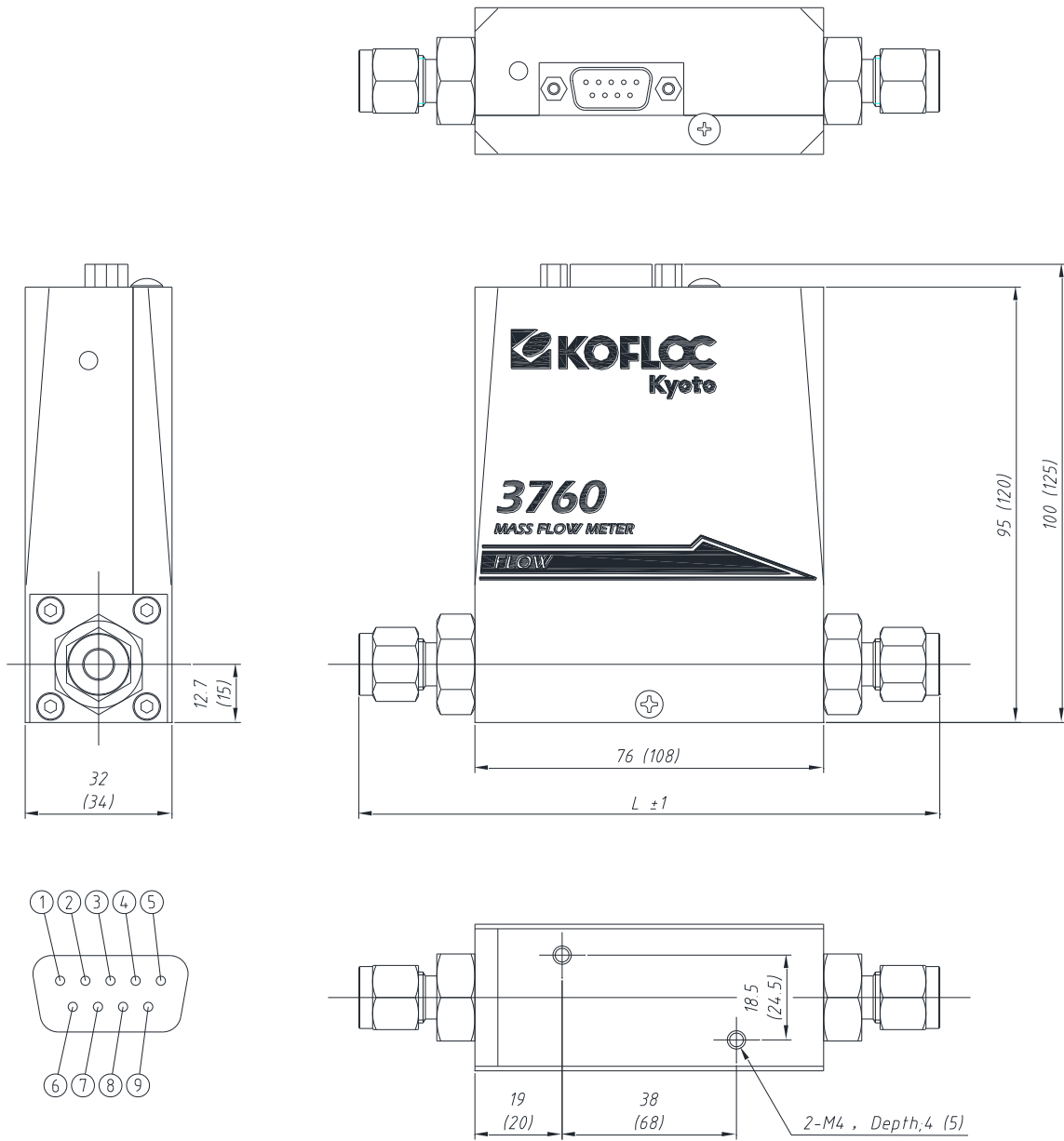

D-sub connector (male)

Fitting	Dimension L(mm)
1/8" F900	122.8 (-)
1/4" F900	127.4 (159.4)
3/8" F900	130.4 (162.4)
1/4" UJR	123.8 (155.8)
Rc 1/4	102 (134)

Indicated in ( ) denote the dimensions for Model 3765

Pin No.	Signal Name
1	NC
2	Output Signal
3	Power +15VDC
4	Power Common
5	Power -15VDC
6	NC
7	Signal Common
8	NC
9	NC

**Note:** Please do not connect NC terminals of the above table, these terminals were connected to electric circuit in inside.

### 3. Configuration

#### 【3-1 Configuration of the Thermal Mass Flow Meter】

Required power supply to operate the mass flow meter (Model3760 series):

DC constant voltage power supply:  $\pm 15$  VDC( $\pm 5\%$ ), +100 mA/-100 mA

1) Peripheral equipment of the mass flow meter

- ① DC power supply: PSK-1FB, AC85 – 132 V (50/60 Hz), max 1A
- ② Flow rate indicator DPM-3 +5 VDC $\pm 5\%$  120 mA

One set of special connecting cables (If a cable longer than 1 m is required, please contact KOFLOC.)

2) Electric wiring diagram of the mass flow meter Model 3760series.

Example: A combination of Model 3760series and PSK-1FB and DPM-3

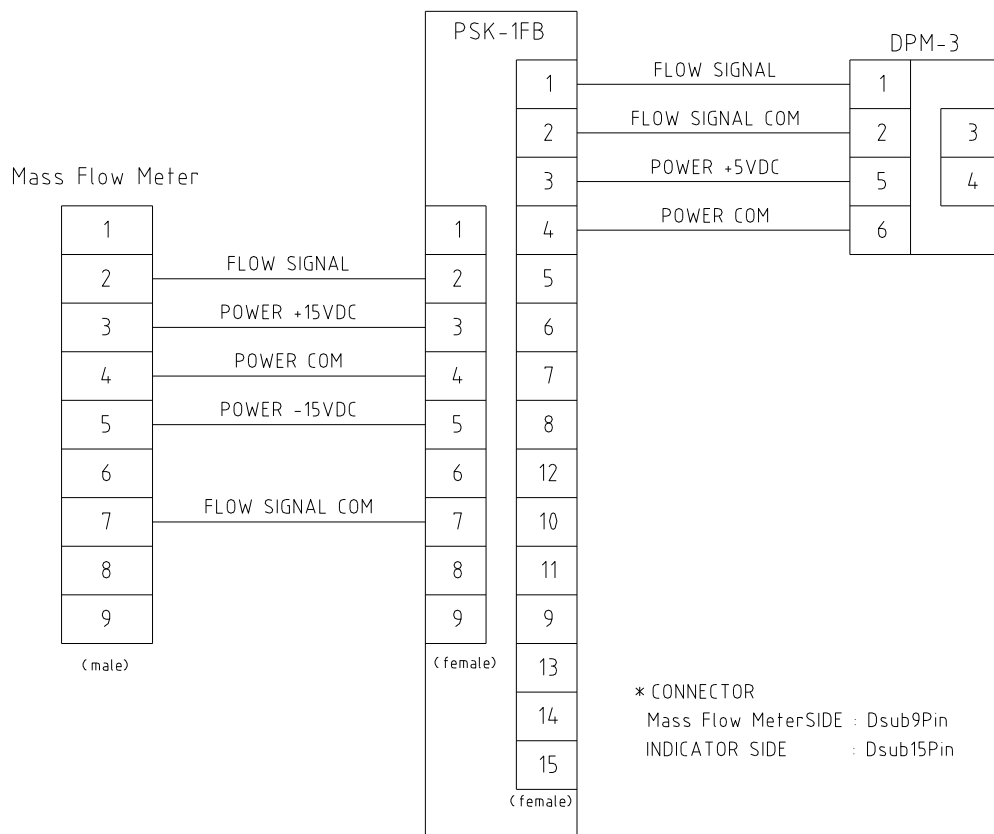



#### 【3-2 Precautions】

- 1) Use clean and dry gas with the mass flow meter. The dryness condition must be a dew point below  $-20^{\circ}\text{C}$  at atmospheric pressure.
- 2) A 100-micron filter is installed at the gas inlet. However, if the meter is to be used in a line where dust and mist might be produced, install a filter of about 10-micron in front of the meter to remove them.

#### 4. Installation

Install the meter in a place that is free of dust, dirt and water and take measures to prevent insulation failure due to condensation. If the temperature of the installation site is likely to rise due to equipment around the meter, provide necessary precautions such as installing a cooling fan to ensure good ventilation. Do not install the meter in a place that is subjected to vibration constantly, because vibration may cause a contact failure of cable connections.

 <b>CAUTION</b>	
<ul style="list-style-type: none"> <li>• <b>Never install the meter in a damp or humid place. Hazard of electric shock.</b></li> </ul>	
<ul style="list-style-type: none"> <li>• <b>Do not install the meter in a place where the ambient temperature may rise excessively. Such a place will cause the temperature of the internal circuit to rise and damage it.</b></li> </ul>	
<ul style="list-style-type: none"> <li>• <b>The installation of the meter in a place that is subjected to vibration constantly may cause a contact failure of cable connections.</b></li> </ul>	

##### 【4-1 Installation Site】

- 1) The mass flow meter is designed for indoor use.  
Never install the meter in a place where it may be wetted. The meter may fail.  
Install the meter in a place that is well ventilated and has little change in humidity.
- 2) Install the meter in a place free of vibration and impact.
- 3) Do not install the meter in a place that is under direct sunlight or very hot or humid.
- 4) Install the meter in a place free of dust.
- 5) Install the meter in a place free of corrosive gases.
- 6) Install the meter in a place free of strong electric or magnetic field.
- 7) Be sure to conduct leak tests of the piping after installation.
- 8) Be sure to install the meter horizontally.
- 9) Always use the special connecting cables.  
(The use of a cable longer than 1 m may disable accurate measurement of the flow rate due to a voltage drop.)

Note that the use of the meter out of the specifications is a cause of failure.

**【4-2 Contamination of the Piping System】**

Be sure to use well-cleaned pipes and joints for piping. A standard filter has been installed. However, if a large amount of dust adheres, the gas flow will be disturbed. In particular, if air from a compressor or blower fan is used, it is likely that a large amount of oil mist and water may enter the meter. In such a case, always install an oil filter or water removing filter in front of the meter.

**【4-3 Installation Posture】**

Install the meter horizontally.

Lay piping so that the gas inlet and outlet are positioned as indicated on the ID plate.

**【4-4 Installation Method】**

- 1) For installation, utilize the mounting threaded holes on the bottom of the meter block.
- 2) The standard piping connection is 1/4"Swagelok (MODEL3765 is 3/8"Swagelok). Use suitable joints and be sure that they won't leak.

**【4-5 Wiring】**

For a detailed description of wiring, refer to 3. Configuration.

Be sure to use special connecting cables.

Be sure to insert the connectors firmly to the designated places.

## ***5. Operation***

**【5-1 Warming Up】**

After the power was turned on, warm up the meter for 15 minutes or longer with the supply of gas stopped.

If the meter is not warmed up, the measuring accuracy will deteriorate.

**【5-2 Zero/Span Calibration】**

If the user has the reference flow meter, the span may be calibrated. If no reference meter is available, conduct the zero calibration only.

**1) Zero calibration**

When the indication has become stable with gas shut off after the meter was warmed up, using a small screwdriver, adjust the "ZERO" variable resistor installed on the top of the case to zero. Be sure that the indicated value or the output becomes zero.

**2) Span calibration**

If the reference meter is not available, never tinker with the "SPAN" variable resistor. Connect the reference flow meter to the gas outlet.

With Model3760series, adjust the "SPAN" variable resistor so that when gas is let flow at the full-scale rate, the flow rate signal output becomes 5 VDC.

If the user does not have the reference flow meter, never tinker with the "SPAN" variable resistor.

**【5-3 Run】**

Model 3760series has been set ready for measurement. It outputs flow rate signals from 0 to 5 VDC for flow rates from zero to the full scale.

**【5-4 Precautions for Use】**

## 1) Calibration of actual gases

For gases other than air, N<sub>2</sub>, O<sub>2</sub>, H<sub>2</sub>, He, Ar and CO<sub>2</sub>, actual gas calibration has been conducted. Other gases are calibrated by use of a conversion factor.

If gases not listed in the specifications are to be used, always test the corrosion resistance of the areas in contact with gas.

## 2) Gas stop

Install a stop valve on the gas inlet or outlet.

**【5-5 Gases Not Listed in Specifications (Conversion Factor)】**

If the thermal mass flow meter that has been calibrated with one type of gas is used for other gas, the indicated value does not match the actual flow rate.



For example, if He is let flow to the meter that has been calibrated with N<sub>2</sub>, the actual flow rate is 1.43 times the indicated flow rate.

For detailed data of the conversion factors, please contact KOFLOC.

## 6. Troubleshooting

If the meter is considered to have failed, in order to prevent short circuit accidents, never use the connector pins of the meter to check output voltages, but be sure to use such safe places as the check terminals of the connected equipment.

If the meter failed, please contact KOFLOC.

	<b>DANGER</b>
<p><b><u>Never disassemble the meter. Touching the inside of the meter may cause electric shock.</u></b></p>	
	 

**【6-1 No Output】**

1	No power	Check the output of the DC power supply.
2	Connector connection failure	Check to see if the connectors are fitted correctly.
3	Cable breakage	Check the continuity with a tester.
4	No gas flow	Check the gas source pressure and gas flow.
5	Clogged piping	Check the solenoid valve, etc. after the outlet.
6	Clogged sensor pipe	Please contact KOFLOC.
7	Sensor amp. failure	Please contact KOFLOC.
8	Indication meter failure	Replace the meter.

**【6-2 Unstable Flow Rate Indication】**

1	Source pressure valve faulty	Check the supply adjust valve.
2	Constant flow valve faulty	Check the valve.
3	Sensor amp. failure	Please contact KOFLOC.
4	Power supply faulty	Replace the DC power supply.

**【6-3 Significantly Different Flow Rate Indication】**

1	Span calibration error	Calibrate the span with the reference flow meter.
2	Gas leak	Piping ..... Stop the leak. Sensor, valve ..... Contact KOFLOC.

**【6-4 Significantly Different Zero】**

1	Incorrect power supply voltage	Replace the power supply.
2	Sensor faulty	Please contact KOFLOC.

**7. Maintenance****【7-1 Zero/Span Calibration】**

If the user can use the reference flow meter, calibrate both the zero and span. If not, calibrate the zero only.

**【7-2 Cleaning the Inlet and Outlet Joints】**

Clean the inlet and outlet joints. They should be removed in a clean place where dust will not enter the block. During maintenance, never disassemble the sensor.

If it is disassembled, the initial performance cannot be guaranteed.

**KOFLOC Corp.**

URL : <http://www.kofloc.co.jp>