



# Flowmeter Instruction Manual

Resin Flowmeter  
Model RK20T Series

Thank you for your selection of “KOFLOC Area Flow Meter.”

Prior to use, read this manual thoroughly to ensure your new meter will work to its fullest capacity.



## Caution

This flowmeter is designed to control the flow under the following conditions of use:

Max. working pressure: 0.7 MPa(G)

Working temperature: 10 to 65°C (No condensation)

The use of the flowmeter with fluids other than those described on the flowmeter such as toxic gases and corrosive fluids or at temperatures or pressures above the maximum allowable levels may cause personal injury. Never use the flowmeter in such a manner. Also note that if solenoid valves are installed before and after the flowmeter and they are opened/closed under pressure, a rapid velocity change may cause the float to jump up to break the acrylic tube. Ensure that a rapid pressure change will not occur.

## Foreword

Thank you for your selection of Model RK20T Series.

- The contents of the manual are subject to change without notice.
- The manual has been created meticulously. Should, however, you notice any deficiencies, errors or omissions, you are kindly requested to notify us.
- The warranty period of this product is one (1) year after shipment.
- Failures attributable to KOFLOC which may occur during the warranty period will be remedied free of charge.
- KOFLOC shall not be held responsible whatsoever for breakdown or trouble of equipment which results from negligence of the precautions described in this manual or using the product by methods other than the described procedures.

## 1. Features

RK20T is a resin flowmeter designed to control AIR/N<sub>2</sub> (7 rates) and WATER (5 rates) by the same size. Compared with conventional metallic flowmeters, this flowmeter is smaller and lower in cost. Two types, one with a valve and one without a valve are available.

If you have questions about the flowmeter, please contact us.

## 2. Installation and Piping

### 2.1. Installation

The standard installation method of this product is panel surface mounting; the joint connecting part is fitted to the opening of the panel from the front side and secured with the included mounting nuts from the back side.

This product comes with two mounting nuts each on the top and bottom sides as a standard feature. Remove one each on each side, insert the joint connecting part to the opening of the panel and secure it with mounting nuts so as to sandwich the panel. This is necessary to protect the body from damage due to load that is applied when the nuts are tightened.

Accordingly, our mounting nuts of the flow meter side, you are requested to note you do not overtighten to the body side. (Inside nuts do not need to be in close contact with the flowmeter body completely, tightening torque is also acceptable by hand tightening. It should be thank you less than the maximum  $2\text{N} \cdot \text{m}$ . Please be fixed outside nuts on the panel at the recommended value in  $6 \sim 15\text{N} \cdot \text{m}$  torque.) In addition, please refer panel processing dimension to drawing described below. Install the flowmeter vertically to ensure accurate measurement of flow. Also minimize vibration and pulsating flow. They will affect the measuring accuracy adversely.

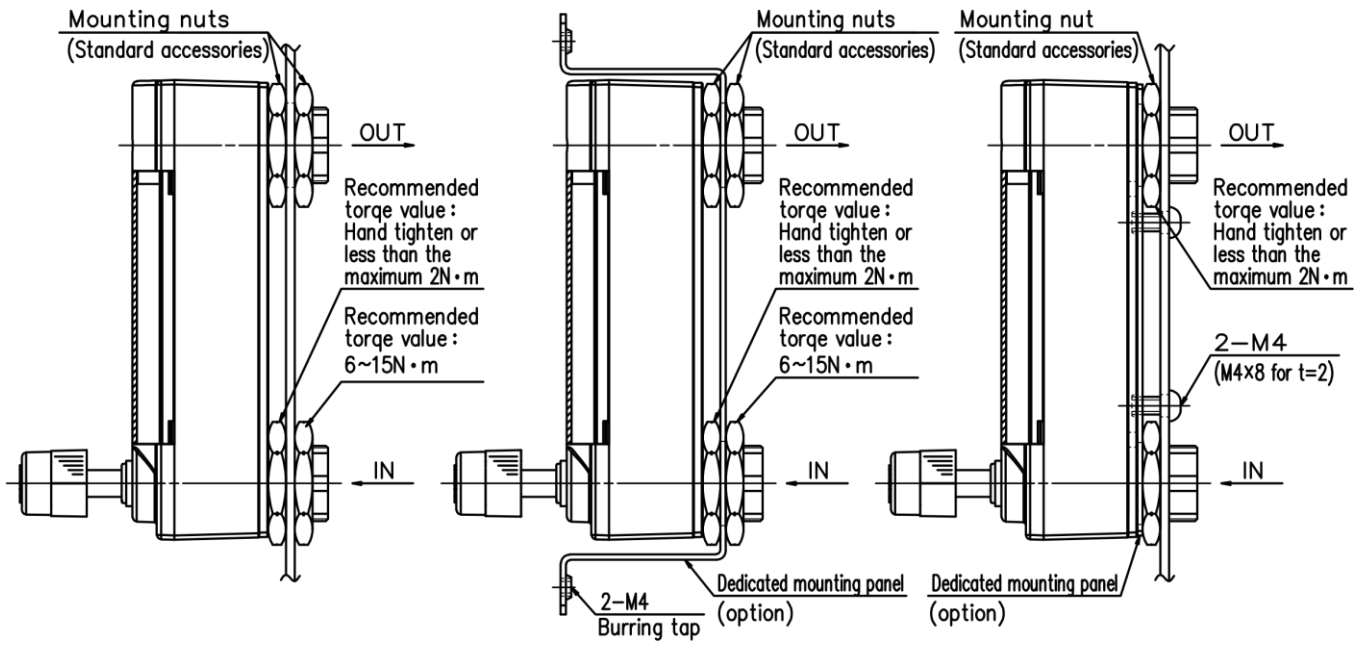

Standard Specifications  
(Panel surface mounting)

Options  
(Panel flush mounting)

Options  
(Panel surface mounting  
— for panel mounting screws )

\* Mounting screws according to the panel thickness, thank you to be prepared by the customer.

## 2.2. Piping

To connect and disconnect piping joints, set a wrench (adjustable wrench) of size 17 at the joint connecting part (flats on the periphery: width across flats 17 mm) of the flowmeter to secure it. (This is necessary to ensure that no load will be applied to the body of the flowmeter.)

After laying piping, test the joint connections for leak. Install a filter on the IN side to prevent foreign matter from entering the equipment. In the case of AIR/N<sub>2</sub>, use dry gas only. Use the flowmeter in conditions where no condensation occurs.

When attaching a pipe joint, the joint connection of the flow meter and the entire needle (or the internal flow stopper for the without valve model) may rotate. This is because the connection joint is integrated with the needle (or stopper), and this rotation is not an abnormal operation. Please be assured that this rotation will not cause any leaks or performance problems.

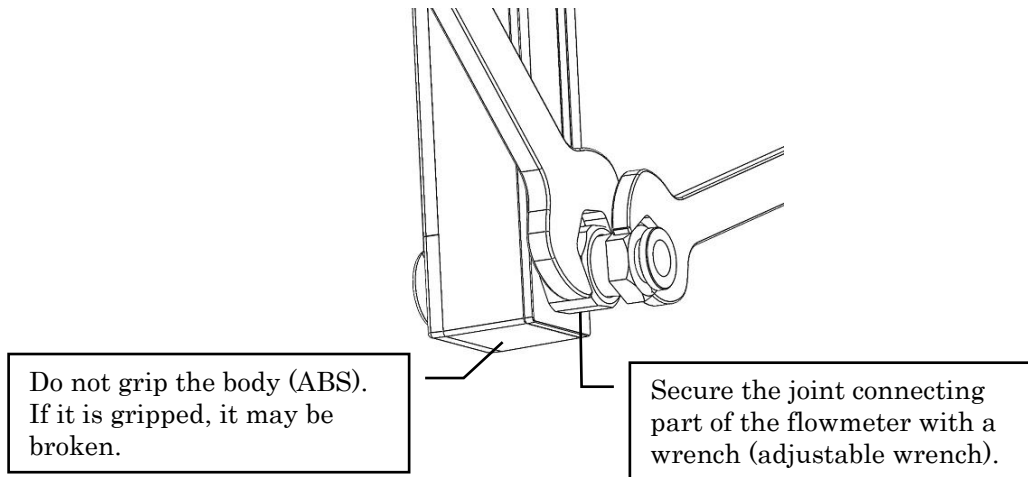

### 3. How to Use

#### 3.1. Basic rule

##### (1) Reading the flow rate

Small to medium flow region: Read the rate at the center of the ball float.

Large region: Read the rate at the uppermost position of the top-shaped float. The tapered tube acts as a lens. Read the rate at the same level ( or at a right angle).

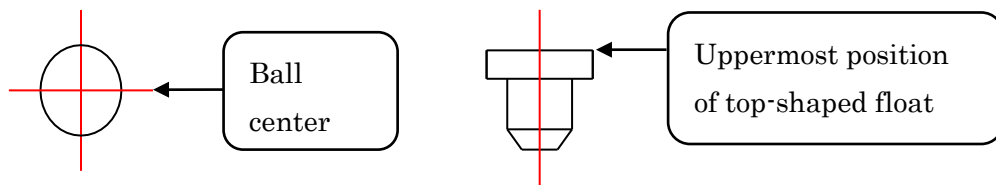

##### (2) Flow rate adjustment

In case of model RK20T, please adjust the flow rate by turning the handle of the needle valve attached. The flow increases by turning it anticlockwise (open) and decreases by turning it clockwise.

#### 3.2. Precautions for use

##### (1) The fluids to use are limited as follows; gas is AIR /N<sub>2</sub> and liquid is WATER.

This product is made of resin. Never use it with corrosive fluids, toxic gases/liquids and fluids/gases containing chemicals and in corrosive atmosphere.

##### (2) The working pressure (IN side pressure) ... Proof pressure: 0.7 MPa.

If the flowmeter is subjected to a rapid change in pressure due, for example, to opening/closing of a solenoid valve or application of a pressure exceeding 0.7 MPa, the flowmeter may be damaged or broken. Ensure that a pressure exceeding 0.7 MPa will never be applied.

Do not install solenoid valves before and after the flowmeter. A rapid change in pressure may cause up/down motion of the float to damage the flowmeter.

- (3) Model RK20T-V (with a valve) does not guarantee the zero stop. If the zero stop does not work, never turn the valve in the closing direction by undue force. The needle part may be damaged to disable flow control. If the zero stop is required, be sure to install a stop valve before this product.
- (4) Please note that when measuring the flow rate of water, the float may not stay in a position, but may become unstable in some rare cases. If this happens, open the flow control valve to cause the float to contact the top stopper and then adjust the valve so that the float will gradually come down to the position. If the float is still unstable, repeat the above operation again.
- (5) This flowmeter is designed for simplified checking of flow. For more stable and accurate flow regulation, an upper model such as RK1250 is recommended. In particular, since AIR/N<sub>2</sub>: 0.5L/MIN spec & 1L/MIN spec and WATER: 25mL/MIN spec are minute flow regulation, the flow may be affected by changes in temperature and pressure. For stable flow over long hours, an upper model such as RK1250 is recommended.

#### 4. Specifications — RK20T —

##### 【Rated specifications】

Fluid	AIR / N <sub>2</sub>	WATER
Flow rate	0.05 ~ 0.5 L/min	2.5 ~ 25 mL/min
	0.15 ~ 1.0 L/min	30 ~ 300 mL/min
	0.5 ~ 5.0 L/min	100 ~ 800 mL/min
	1.0 ~ 10 L/min	200 ~ 1600 mL/min
	2.5 ~ 25 L/min	500 ~ 1800 mL/min
	5 ~ 50 L/min	
	20 ~ 100 L/min	
Accuracy	FS ± 6%	
Max. working pressure	0.7MPa(G)	
Max. working temperature	65°C (Note1)	
Materials in contact with fluid	ABS, acrylic resin, SUS303, hard glass or SUS316, FKM, POM, (SUS304)	
Connection	Rc1/4	

Note1: Only FS0.5L / min specifications should be used in an environment of 10-40 ° C.  
 Note2: The flow rates are indicated at 20°C of air (atmospheric pressure) and 20°C of water.

**【RK20T dimensions】**

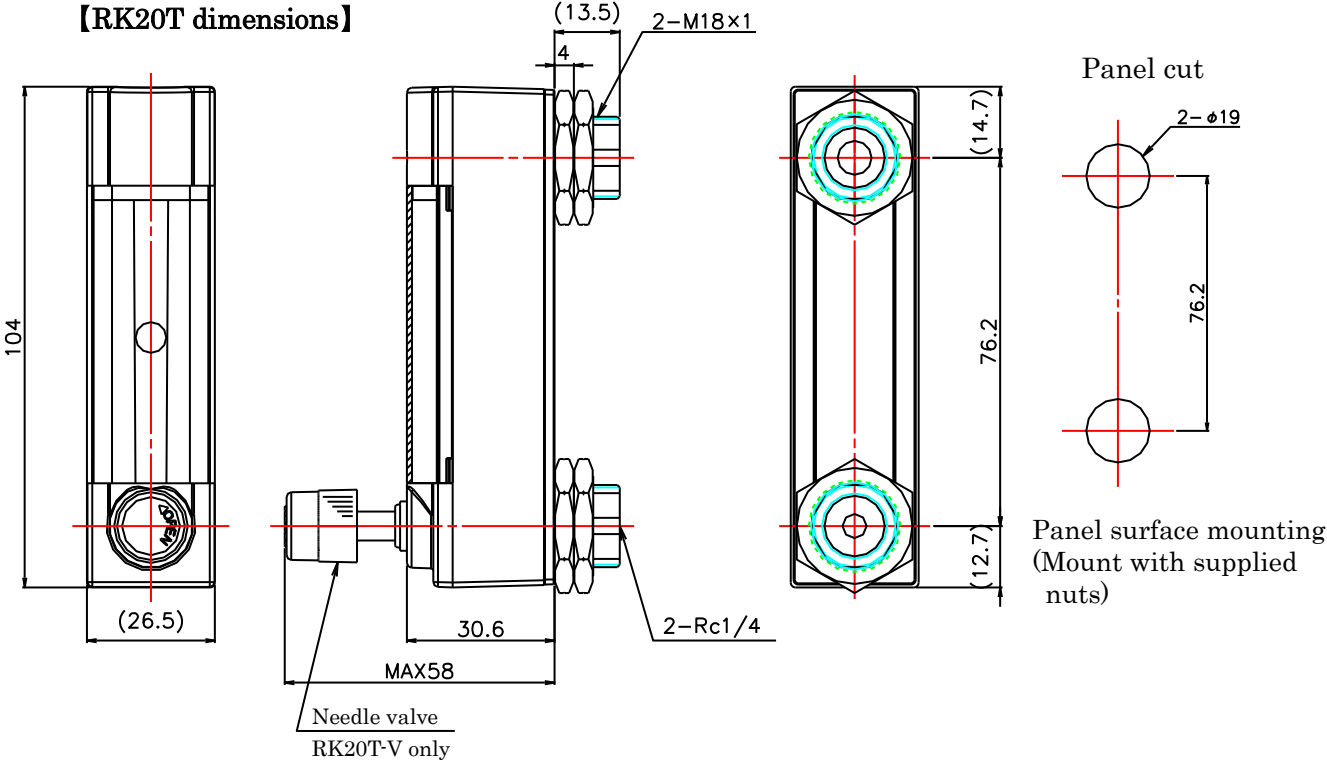

(Options : Panel flush mounting)

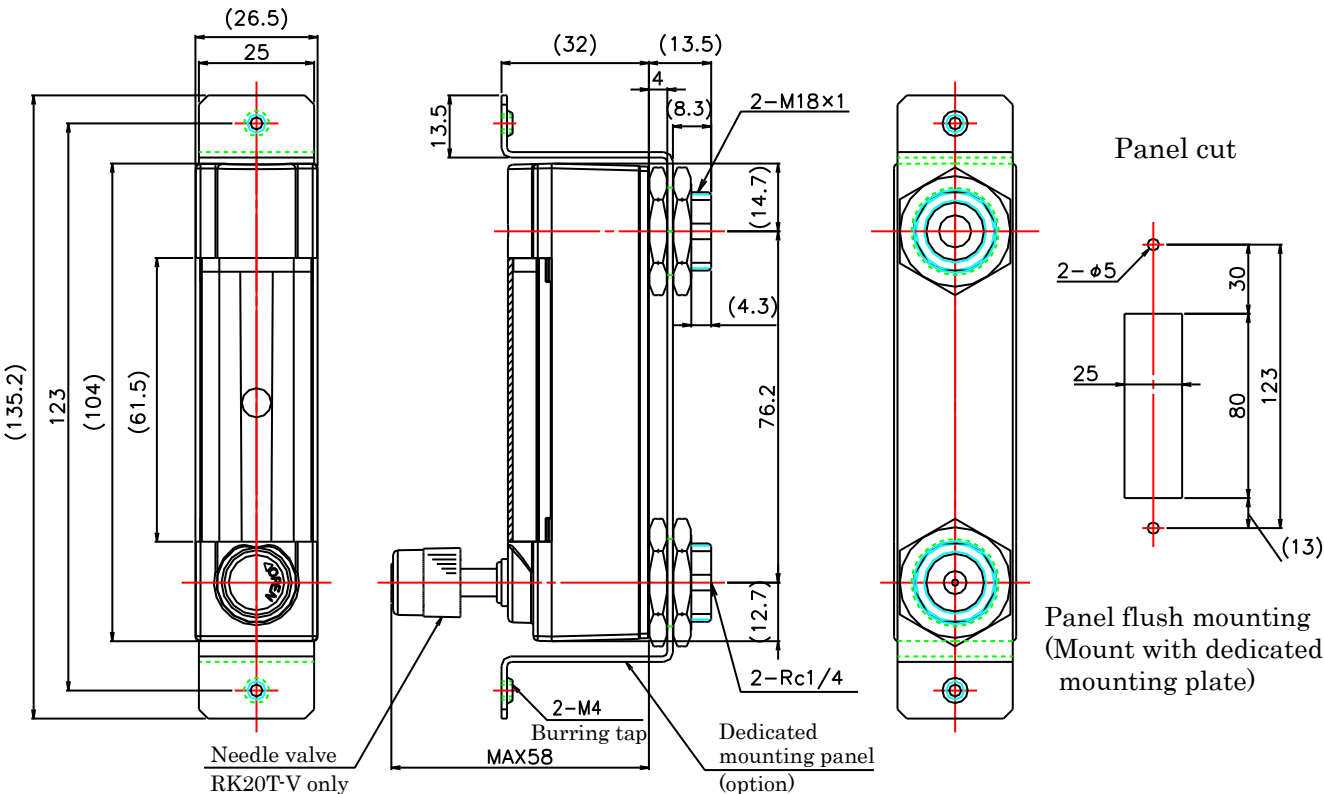

(Options : Panel surface mounting — for panel mounting screws)

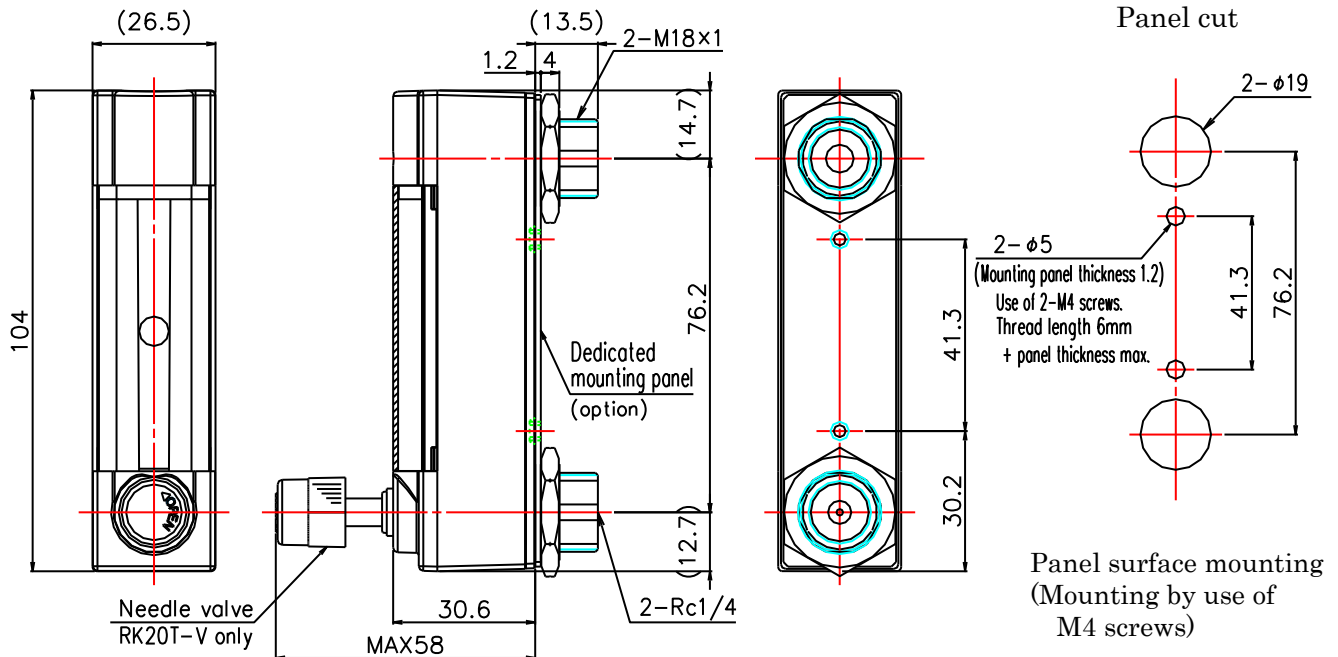

## 5. Troubleshooting

\* Float will not move:

Dust/dirt is sticking. Conduct purge with clean air or N<sub>2</sub>.

\* Float moving is unstable:

Please check this comes from real flow rate deviation or not.

\* The flow rate cannot be set:

- 1) Check dusts or particles getting inside the gap or not.
- 2) Check the piping for fluid leak.
- 3) Check the lack of inlet pressure.

## 6. Corrective Action and Repair

If the product fails due to a cause attributable to Kofloc within one year after it was shipped, the failed product will be replaced with a new one when the failed product is received by us. Please note that this product is basically not covered by our repair policy and it is therefore requested that, as a general rule, a new product be purchased should your product fail. This policy is based on the product concept of low cost priority.

## 7. Storage

(1) The storage place must meet the following conditions:

- A place where the flow meter will not be wetted by rains or water.
- A place where the flow meter will not be subjected to vibration and impact.
- Temperature: 5 ~ 45°C
- Humidity: 5 ~ 90%RH
- A place where no corrosive gases are present.

(2) When the flow meter is not used, pack it and then store it.

## 8. Product Warranty Policy

Thank you for your continued support of KOFLOC products.

Unless specified otherwise in quotations, contracts or specifications when you place orders for KOFLOC products, the following warranty policy will apply.

Warranty Policy:

### ① Warranty period

The warranty period is one (1) year from shipment, provided that the product is used within the KOFLOC specification.

### ② Scope of warranty

If the KOFLOC product fails during the warranty period due to a cause attributable to KOFLOC, KOFLOC shall, at its option and expense, provide a replacement product or repair the failed product at the KOFLOC factory.

This warranty, however, shall not cover damages due to a cause not attributable to KOFLOC; opportunity loss, lost profit, secondary disaster, accident compensation suffered by the customer and damage to other equipment and any other damages due to a failure of the KOFLOC product.

### ③ Non-warranty

The warranty shall not apply to the following failures and damages even if they occur during the warranty period:

- ① Failure due to misuse or improper repair or modification. (Failures resulting from use under conditions different from the manufacturing specifications are included.)
- ② Damage and failure due to dropping of the product after purchase.
- ③ Failure due to fire, earthquake, flood, lightning or other natural disaster; or riot, war or the like.
- ④ Failure due to intrusion of foreign matter from piping.

- ⑤ Failure caused by a specific problem due to combination with other incorporated equipment.
- ⑥ Other failures and damages which are considered not attributable to KOFLOC.

Please be aware that the warranty shall not cover opportunity loss suffered by you or your customer or damage to other equipment or any other damages due to a failure of the KOFLOC product.