



Metal Seal Mass Flow Meter / Mass Flow Controller

MODEL 5410/5400

Instruction Manual

KOFLOC Corp.

Read this page before proceeding!

Read this instruction manual fully before installation and application so as to maintain the performance and safety of the product – Model5410 mass flow meter or Model5400 mass flow controller. This enables preventing accidents and breakages of the product due to an erroneous application method. If the product has a malfunction or its readjust is required, please notify our branch or agent near to you of the content of your requirements. As the skilled service men properly correspond to your requirements, please be sure to obey their instructions. If you make a repair or remodeling by yourself, a critical accident may occur and together it turns difficult to secure the normal warranty. So pay particular attention to it. This manual may be partially varied in future without prior notice for improvements. For delivery of the products, all possible cautions have been paid. Should any defective points, errors or description omissions exist in the manual, notify us of them.

The following are picture indications for cautions to be noted-observed before application or for safe application of the product. They have been made in the instruction manual and on the specific portions of the product so as to ensure correct application of the product and prevent injuries to you or other workers or damages to the properties.

DANGER : INDICATES AN IMMINENT HAZARDOUSNESS WHICH, IF NOT AVOIDED, WILL RESULT IN DEATH OR SERIOUS INJURY. THIS SIGNAL WORD IS TO BE LIMITED TO THE MOST EXTREME SITUATION.

WARNING : INDICATES A POTENTIAL HAZARDOUSNESS WHICH, IF NOT AVOIDED, COULD RESULT IN DEATH OR SERIOUS INJURY.

CAUTION : INDICATES A POTENTIAL HAZARDOUSNESS WHICH, IF NOT AVOIDED, MAY RESULT IN MINOR OR MODERATE INJURY. IT MAY ALSO BE USED TO ALERT AGAINST UNSAFE PRACTICES.

Page**CONTENTS:**

1. Specifications -----	3
1-1. Specifications -----	3
1-2. Unit of Flow-----	3
2. Principle of Operation -----	4
3. Standard Configuration and Wiring Connection -----	5
3-1. Standard Configuration -----	5
3-2. Electric Connection Diagram -----	5
3-3. Cautions for Wiring Connection -----	6
4. Installation and Piping -----	6
4-1. Storage and Application Environment -----	6
4-2. Piping System Washing -----	7
4-3. In-line Filter -----	7
4-4. Securing of The Operational Pressure -----	7
4-5. Combined Use of The Stop Value -----	8
4-6. Gas Connection -----	8
4-7. Installation -----	8
5. Operational Procedure -----	9
6. Troubleshooting -----	10
7. Dimensions -----	12
8. Cautions for Handling -----	13
9. Product Warranty -----	14

1. Specifications

Model 5400 Metal Seal Mass Flow Controller is a mass flow measurement device designed for accurately and rapidly controlling gases. Model 5410 Series is a mass flow meter with the same body size as Model 5400.

1-1. Specifications

	5400	5410
Flow Ranges (N ₂ equivalent, 20°C, 1atm)	10SCCM-20SLM (freely selectable)	
Response	1sec. or less (0-100% with in ±2% typical)	-
Accuracy	±1.0%F.S.(20°C)	
Repeatability	Within±0.2%F.S. (20°C)	
Control Range	2-100%	-
Differential Pressure	50kPa-300kPa (F.S. ≤5SLM) 100kPa-300kPa (5SLM<F.S.)	-
Pressure Resistance	980kPa	
Leak Integrity	1 x 10 ⁻¹¹ Pam ³ /s He	
Ambient Temperature	0-50°C (Accuracy guaranteed at 15-35°C)	
Flow rate input signals	0- 5VDC (Input impedance:1MΩ or more).	-
Flow rate output signals	0-5VDC (Minimum load resistance :250kΩ or more)	
Required power supply	+15VDC (±5%)100mA, -15VDC (±5%) 200mA	+15VDC (±5%)100mA, -15VDC (±5%) 100mA
Electrical Connection	Dsub-9Pin connector as per KFC Standard (Compliant with SEMI Standard)	
Joint (Main unit bore)	Standard: 1/4VCR equivalent Option : 1/4SWL	
Valve Type	Proportional solenoid valve (Normally-closed type)	-
Configuration material	SUS316L, Ni, PTFE, Ni-Co	

1-2. Unit of Flow

Our mass flow controller is based on the SEMIE12-91 (Semi-standard).

The applied unit is SLM (Standard Liter per Minute) or SCCM (Standard Cubic per Minute). The status of this gas is the same as the reference(normal) conditions of 20°C, 101.325kPa(abs). If the applied flow unit and definition thereon differ, inquire us of it or give us your instructions. If the unit you require is a SI unit or unit approved by the current measuring law, we will make a production on the basis of the unit you require.

2. Principal of Operational

The detection sensor for Mass Flow is wound thermo-resistance wires on the outsides of the two positions (upstream and downstream) of the metal tubing. Flowing a certain quantity of current into its wires and self-heating them allow the thermo-resistance wires on the two positions to have a balance at the same temperature during gas with no flow in the metal tubing. When gas flows in this metal tubing, the thermo-resistance wires on the up- per flow side is deprived of heat by the gas, thereby lowering the temperature. The downstream is conveyed the heat of the upstream. This raises the temperature and breaks the initial balance, thus also causing a difference between the resistances. The temperature difference of these positions grows in proportion to the gas flow amount and a volume of the heat capacity specified with the specific gravity and specific heat determines the ratio of the temperature difference change. The change of the gas flow amount is caught as a temperature change, that is, a change of the resistance value, thus detecting the Mass Flow. (=Principal of the thermal flow sensor).

The change of the Mass Flow is represented as a change of the voltage signal by the electronic circuit, through utilization of this principal.

Selecting-mounting a bypass capillary for making the flow detecting sensor bypass the flow limits the flow rating to be determined. In addition, mount a comparative control circuit onto the combination of the flow detection sensor and control valve for this Mass Flow, thereby providing it with signals for setting the flow detection sensor and flow. The comparative control circuit compares these two signals. Then if the output signal is smaller than the setting signal, turn the opening of the control valve greater, thus changing the current added to the solenoid valve. The standard valve is of normal closing type. With the power not-being ON, the flow route is closed.

Principal of Operation

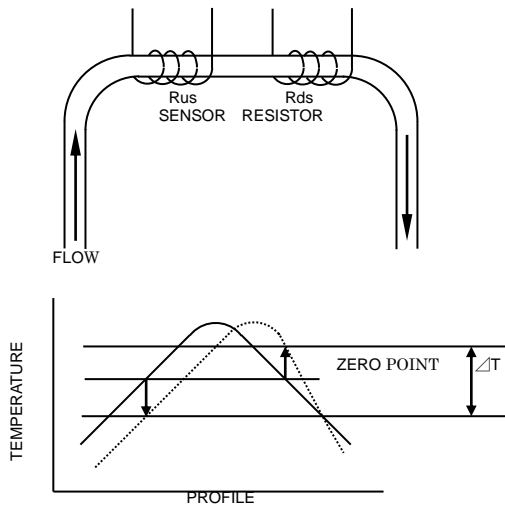

Flow Control System Block Diagram

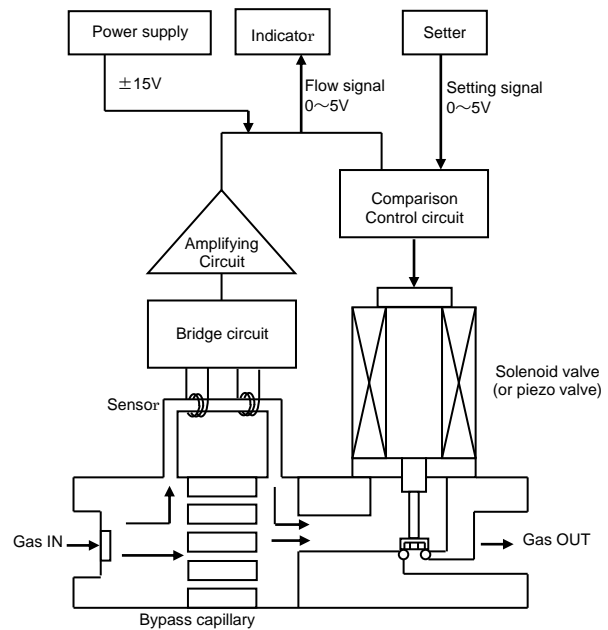

3. Standard Configuration and Wiring Connection

3-1. Standard Configuration

Voltage and capacity required for operating model 5400 controller. (or model 5410 meter)
 DC constant voltage and power source: $\pm 15V$ DC +100mA -200mA (model 5410 -100mA)

Peripheral appliances (Basic examples)

- ①DC power source : PSK-1FB 85-132V AC(50/60Hz) 0.8A
- ②Flow indicator : DPM-3 +5V($\pm 5\%$) DC 120mA
- ③Flow setting appliance : CK-1A(Resistance:10k Ω)
- ④Special-purpose : One set of special connecting cables

(If you require a cable longer than 1 meter, please contact us.)

3-2. Electric Connection Diagram

Example: A combination of Model5400/Model5410 and ①—③ mentioned above.

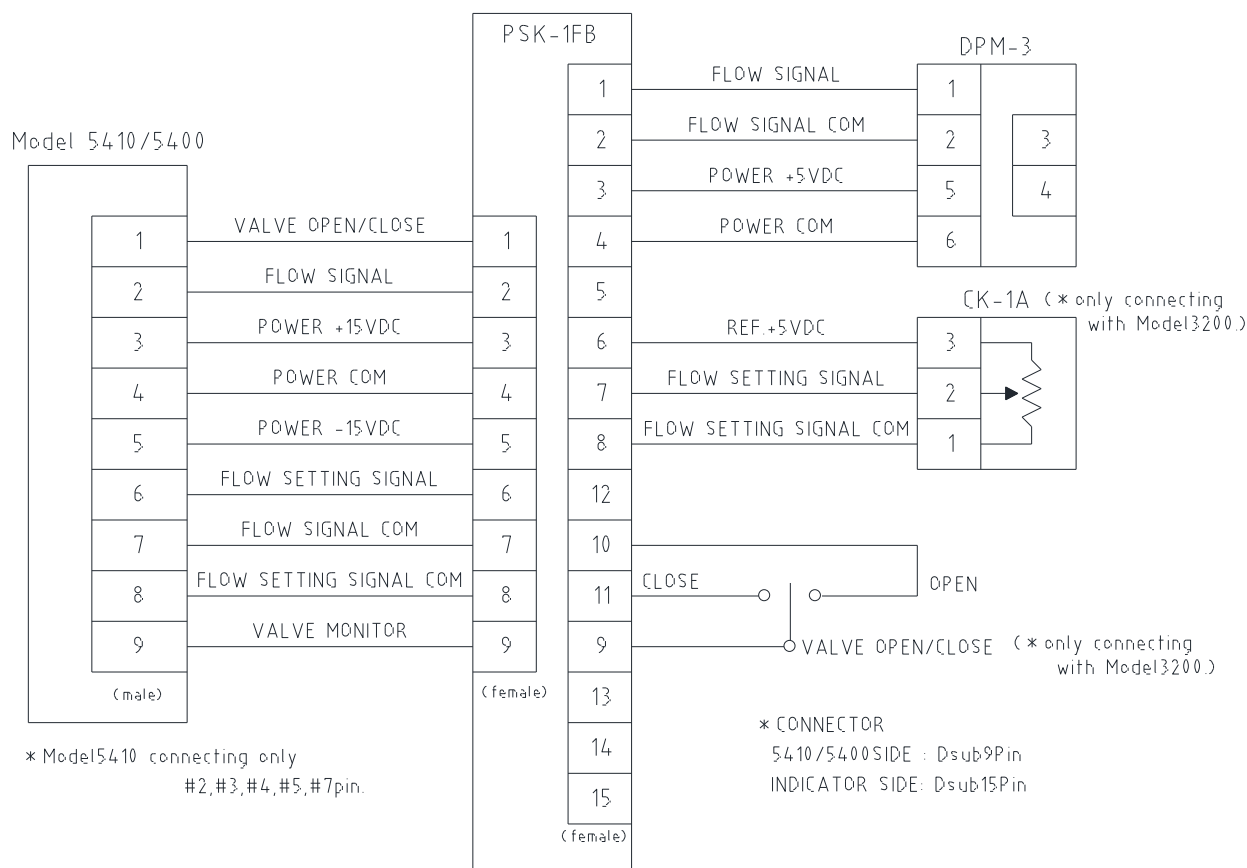

3-3. Cautions for Wiring Connection

- CAUTION** : The flow setting input of this instrument Model 5400 is ordinarily a differential input. Pin 8 is not connected to other COM line in the MFC interior. When operating the setting input signal on the signal end for the purpose other than the use of the appliance, be sure to connect Pin 8 with other common line (Pin 4 or 7).
- CAUTION** : The flow signal output from this instrument Model 5400 reaches +15V DC near the power voltage during valve full opening. So the circuit to be connected shall be its-point-considered.
- CAUTION** : The pin arrangement of this instrument Model 5410 / Model 5400 is in conformity with the SEMI standards. Our old types (models 3650 and 3750) and other corporations' types exist, which have connectors on the same D-sub 9 pin standards, but do not conform to the SEMI standards. As the erroneous connection causes a critical malfunction, please check for it.

4. Installation and Piping

For design and piping construction of the instrument and piping of the system including the mass flow controller, fully read the following matters and perform job with particular attention being paid.

4-1. Storage and Application Environments

Applying this instrument near the equipment such as high frequency induction furnace or in the place in which various power systems are concentrated may easily intrude noise into the Mass Flow Controller, thereby interfering normal operation.

Eliminate the noise and prevent its intrusion before application. Avoid application in a place having a difficulty in maintaining such normal operation.

Avoid storage or application outdoor in direct contact with wind-rain or dusts.

Avoid application under the environment in which drops of water directly fall, or dusts has been accumulated, or in the atmosphere having a high temperature or corrosive gases. The application in these places may deteriorate or corrode the electronic parts or cause a connection fault of the cable connection unit.

Avoid storage or application in a place in which the ambient temperature exceeds 60°C or vibrations occur. When using the controller with gas being actually flowed, the gas temperature and ambient temperature must be within 0–50°C.

Application out of this range may cause damages of the performance. So pay particular attention to it.

- CAUTION** : When installing this instrument, avoid the environment in which an ambient noise generating source exists, and drops of water or dusts have accumulated, or the atmosphere in which a high temperature and corrosive gas exist. Ignoring it may cause a critical malfunction.

4-2. Washing of The Piping System

Fully internally wash the pipes and appliances (such as the pressure regulator, pressure gauge and stop valve) used for piping system before the applications there- of. Mixing of dusts, rusts, oil and water makes an intrusion of their substances into the mass flow controller, thus causing an internal clogging, deterioration in performance and erroneous operation.

CAUTION : Never wash the piping system after incorporation of this instrument. Ignoring it may cause a critical malfunction.

4-3. In-line Filter

It is recommend that an In-Line be installed upstream from the controller to prevent the possibility of any foreign material entering the flow sensor or control valve. The filtering element should be replaced periodically or ultrasonically cleaned.

When applying the air fed out of the compressor or fan, a large quantity of oil mist or drops of water may intrude. So mount an oil filter or water-eliminating filter on the front stage.

Recommended filter size	
Maximum flow	Filter size
10-20SLM	15 μ

4-4. Securing of The Operational Pressure

When operating Model 5400 Mass Flow Controller correctly, design the piping system so that the pressure difference between the inlet and outlet sides is always in the range of 50kPa-300kPa(5 < F.S. \leq 20SLM model: 100-300kPa) and additionally gets stable. It is necessary to mount a pressure regulator on the proper portion of the piping reaching the inlet side of this instrument, thereby enabling adjustment of the pressure on the inlet side of this instrument. It may also get necessary to mount a backpressure regulator on the proper portion of the piping on the outlet side of this instrument so as to keep the differential pressure between the inlet and outlet securely in the range mentioned-above. In this case, it is recommended to mount a bypass between the inlet and outlet sides.

4-5. Combined Use of The Stop Valve

The control valve of the Mass Flow Controller is intended for minute flow control, not-functioning as a complete shut-off valve(stop valve). Even when turning the flow setting to zero (0), a small quantity of gas may flow via the orifice of the control valve. In order to stop the gas flow, additionally mount a stop valve (solenoid type or manual type) on the proper portion of the piping on the inlet side or outlet side of the Mass Flow Controller.

4-6. Gas Connection

The standard joints of Model 5410 Meter / Model 5400 Controller are 1/4 VCR or the equivalent on both of the inlet and outlet.

4-7. Installation

When designing the piping system employing the Mass Flow Meter / Controller, pay particular attention to that this instrument may have to be removed for maintenance jobs such as inspection and disassembling washing. Take into full consideration the arrangement having a space enabling easy removing and reinstallation piping jobs. During installing this instrument, pay particular attention so that no foreign matters intrude from the inlet or outlet. Hold attaching the protective caps on the both ends until the installation.

[Installation procedure]

- a. Install Model 5410 Meter / Model 5400 Controller in a clean-dried place in which no impacts and vibrations occur.
- b. Secure a sufficient space allowing span or zero-point adjustments.
- c. Perform piping so that it can be easily removed for request for maintenance service to us.
 Note): Applying toxic gas may cause a contamination or corrosion in the Mass Flow Controller due to a piping leak or improper purging.
 Before the application, fully check to ensure that no leaks exist in the piping, and perform purging with dried N₂ gas.
- d. There exist no limits for installation posture. However, apply Model 5410 Meter / Model 5400 Controller at the physically no forcible status. Install it levelly. In the case of other installation postures, perform zero-point adjustment after the warming-up.
- e. When installing Model 5410 Meter / Model 5400, existence of an angle piping just in front of the controller worsens the accuracy a little.

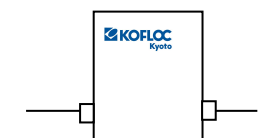

CAUTION : The valve control of model 5400 controller is intended for accurate control, not-having been designed for complete shutting-off. If a complete shutting-off is required, it is recommended to mount a shutting-off valve on the inlet or outlet.

CAUTION : The flow signal output from this instrument Model 5400 reaches +15V DC near the power voltage during valve full opening. So the circuit to be connected shall be its-point-considered.

CAUTION : As Model 5400 Mass Flow Controller does not have a complete shutting-off valve, a solenoid valve may be separately mounted. At that time, a small quantity of gas is confined between the down-flow of the controller and the solenoid valve, thereby causing a surging during driving of the controller. Pay particular attention to it. The surging can be weakened by placing the controller closer to the solenoid valve, or by placing the solenoid valve on the upper-flow side of the controller.

5. Operation Procedure

- Check to ensure that the piping system connection, cable connection and wirings are correct.
- Securely close the mass flow controller with the solenoid valve and manual stop valve so that gas will not flow thereinto.
- Turn ON the power switch and perform warming-up at least for 15 minutes. This is intended to make thermal and electric balances of the sensor, thus creating the stable status.
- When no gases flow, the warming-up is sufficiently conducted and the flow instruction output gets stable, once clockwise turn the knob on the upper portion of MFC with a small female driver so that the indicated valve changes by around 20%F.S and the output changes by around 1V. Next, counterclockwise turn it so that the indicated value gets 0% or 0V. For the adjustment mentioned-above, be sure to make a zero-point adjustment from the plus side so that the indicated value or output gets a minus value.
- If a compensation for errors between our reference calibrator and reference flow meter or a span periodical calibration is required, perform calibration in the following procedure. Ordinarily the calibration is not required. If you don't have a reference flow meter, never move the span pot.
[SPAN CALIBRATION PROCEDURE]:
Connect a reference flow meter to the gas outlet side of the main machine. Add a gas pressure within the range of the applied pressure to the inlet side and set the flow at 100%(5V DC) F.S. After the indicated value gets stable at its status, measure the flow. Turn the span pot so that the indication of the flow meter gets a full-scale flow.
It may take times until the flow gets completely stable. So if the span pot was operated intentionally, waiting for about 5 minutes until measurement of the flow leads to a calibration with a higher accuracy.
- Turn the setting of the pressure regulator to zero (0) and open the stop valve. If the working pressure (inlet side) is below 294kPa, raise it to 294kPa with a pressure regulator. When applying the pressure regulator in combination with the backpressure regulator, beforehand open the bypass valve or set the command at around 10%. Then, raise the pressure, while adjusting the inlet pressure regulator and backpressure regulator together. At this time, adjust the backpressure regulator to a higher value. When the pressure reaches the working pressure, fix the inlet pressure regulator, set the command to zero (0) and then, close the bypass valve.
Set the differential pressure between the inlet and outlet sides within the prescribed range, with the backpressure regulator.

6. Troubleshooting

6-1. Troubleshooting and actions for quality assurance, and cautions for maintenance

Trouble	Possible Cause	Check/Corrective Actions
1.The sensor does not output.	a. The power switch is not ON.	1. Ensure that the power indication lamp is lit.
	b. Connection mistake of the indicator and connector.	1. Reconnect the connector. Ensure that each line has a correct color.
	c. Gas does not reach.	1. Ensure that the gas cylinder has an original pressure and the valve is open. 2. Ensure that the solenoid valve and 3-way valve built-in the line normally operate. 3. Ensure that the line filter is not clogged.
	d. Obstacles exist in the outlet piping of the Mass Flow Controller.	1. Check for solenoid valve, 3way valve and air valve.
	e. A forcible closing signal has been input in the Mass Flow Controller.	1. Ensure that no valve forcible closing signals (-15V DC) have been input in Pin NO.1.
	f. Power error	1. Remove the cable and check for $\pm 15V$ DC(Within $\pm 4\%$) with a tester. If the power is not ON, replace the power switch with new one.
	g. Orifice clogging	1. Disassembling washing or replacement is required. In this case, replacement of the sensor is required. Return it to us.
	h. Sensor tube clogging	1. At this time, the gas continuously flows. So check for it. In case, the sensor has to be replaced. Return it to us.
2.The output does not become zero (0).	a. Internal leak or external leak of the control valve.	1. Remove the forward piping of the mass flow controller and discharge the gas. Then ensure that the output becomes zero (0).
	b. Command error or connection error of the external setting appliance.	1. Check for command and external setting appliance wirings.
	c. If the above wirings does not have any error, a sensor error or electronic circuit error exists.	1. Electronic circuit error. Return it to us.
	d. Sensor error or electronic circuit error.	1. The zero-point adjustment also allows application. However, the flow accuracy is lost. The same action as the above 2 is done, so return to us.
3.During gas flow, the flow indications flicker.	a. The supplied pressure on the inlet of the mass flow controller is always unstable.	1. Set the pressure regulator in the inlet and stabilize the pressure.
	b. Operational error of the control valve.	1. Return it to us.
	c. Indicator error.	1. Replacement of the indicator
	d. Connection error of the connector.	1. Ensure that the pin has been properly fit in the connector.

4.The set indication is not made.	a.	Over rising or error of the inlet pressure of the Mass Flow Controller. The differential pressure between the inlet and outlet is not proper.	1.	Provide the proper pressure as specified in the catalogue. Make a proper differential pressure.
	b.	The pressure loss of the piping is greater. Or the clogged filter or check valve has made a greater pressure loss.	2.	Insert a pressure gauge into the front-back of the Mass Flow Controller, and check for proper differential pressure.
	c.	The orifice in the control valve is almost clogged.	3.	If the pressure is raised and the differential pressure gets stable, an orifice clogging is considered a cause.
5.The flow is clearly smaller to the flow indication.	a.	Leak of the piping line.	1.	Check for tightening ignorance, tightening shortage and other leak of the piping line nut with pressure reduction and leak detecting liquid. Additionally tighten the leaking portion to stop the leak.
	b.	Leak of the main machine of the mass flow controller	1.	Same as the above. However, when checking for leak with leak detecting liquid, check only the front-rear joints, excluding the cover interior. After checking, remove the leak detecting liquid completely.
	c.	Clogging of the bypass unit	1.	Replace the bypass unit with new one or return it to us.
6.The flow is clearly greater to the flow indication.	a.	The sensor tube is almost clogged.	1.	Replace the sensor tube unit with new one or return it to us.
7.Also with the command being zero(0), the gas continues flowing.	a.	The set voltage has not yet turned zero(0) through external setting control. Or PC board fault. Wire breakdown of command soldering portion.	1.	Check for operation through changing-over to the command. If the operation gets normal, check for external setting appliance.
			2.	Input a valve forcibly-closing signal(-15V DC) in Pin NO.1 and check for gas stop. If the gas does not stop, adjust the valve or return it to us. If gas stops, the electronic circuit error is considered a cause. Return it to us.
	b.	Internal leak due to dust adhering to the seal of control valve.	1.	Return the valve to us for its disassembling-washing.
	c.	The zero-point voltage has been shifted to the minus.	1.	Zero-point voltage error. See Problem 2.Output does not become zero(0).

6-2. Cautions for maintenance

6-2-1. Zero-point and span calibrations

If you have a reference flow meter, perform both adjustment and calibration of the zero-point and span. If you do not have the meter, adjust only the zero-point.

6-2-2. Joint washing of the inlet and outlet

Remove the joints for washing thereof in an environment as clean as possible so that no dusts will enter the main machine. Never disassemble the sensor and valve. (With regard to the disassembling, it is difficult to warrant the initial performance.)

7. Outside drawing

7-1 The outside drawing of mass flow controller Model5400

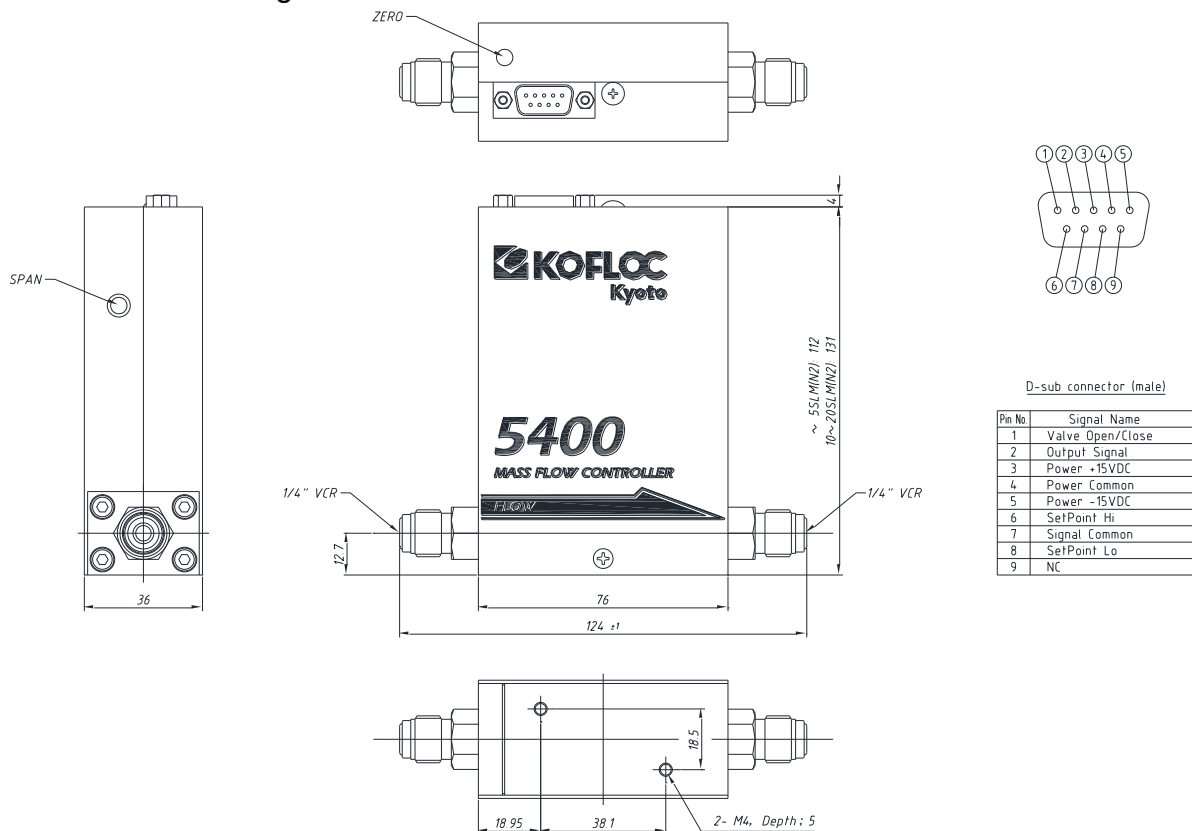

7-1 The outside drawing of mass flow meter Model5410

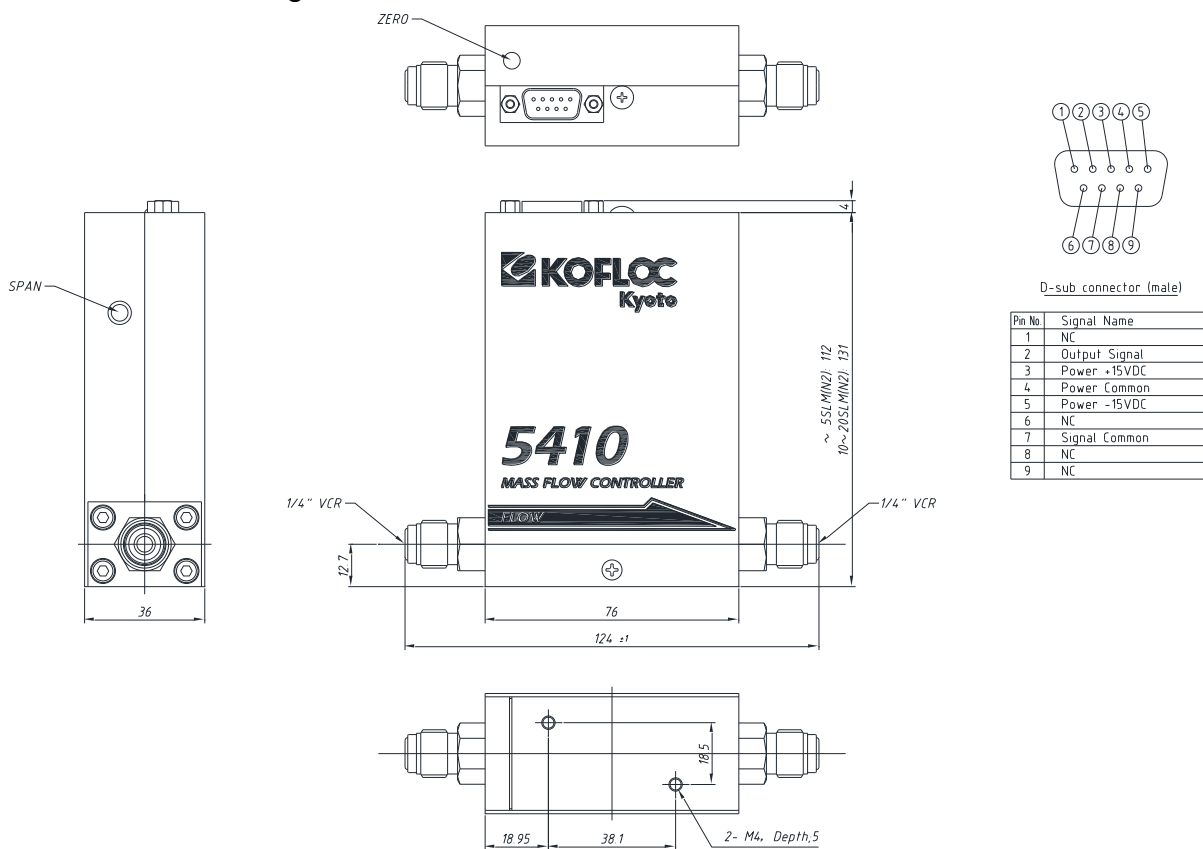

8. Cautions for Handling

8-1. Confirm The Description on The Nameplate.

Model 5410 Mass Flow Meter / Model 5400 Mass Flow Controller you placed an order with us for has been particularly assembled and adjusted according to the specifications.

The applicable gases and flows are described on the nameplate on the rear surface of the case. Check to ensure that they are the same as designated in the specifications.

Inspection items :

- ① Model
- ② Flows : SCCM = milliliter per minute at 20°C : 1 air pressure
(101.325Kpa abs)
SLM = liter per minute at 20°C : 1 air pressure
(101.325Kpa abs)

*We are in conformity with the flow unit of SEMI-E12-91. With regard to other status and reference temperature, separately inquire us of them.

- ③ Name of the fluid
- ④ Existence of the serial NO.

8-2. Cautions for Transportation

Carry our Model 5410 / Model 5400 to the installation place with the shipment packing status being kept as much as possible so as to inhibit its damages by accidents during transportation.

8-3. Recommend Storage Practice

After delivered to you, Model 5410 / Model 5400 may cause an unexpected malfunction due to the longer period's storage. If the longer period's storage is anticipated, pay particular attentions to the following items.

- 1) Store Model 5410 / Model 5400, while keeping the shipment packing status as much as possible.
- 2) Select the storing place meeting the following conditions.
 - ① Place which will be never splashed with rain or water.
 - ② Place on which no vibrations or impacts occur.
 - ③ Place having an ordinary temperature and humidity(around 25°C, 65%) for storage.
 - ④ Place with a little dusts.
 - ⑤ Place with no corrosive gases.
 - ⑥ Place with no strong electric fields or magnetic fields.
- 3) When storing the once-applied equipment, be sure to perform purging with clean air or N₂ gas so that no measurement gases remain in the main machine of the flow meter. Protect the inlet-outlet for measurement gases with a cap so that no dusts are mixed-in.

9. Product warranty

1. The contents of warranty

① Warranty period

The warrant period shall be one year after the shipment.

② Warranty range

If a malfunction of the product you purchased occurs because of our responsible reasons, offer of substitute or it will be charge-free repaired in our factory. But if a malfunction of the machine occurs due to the following reasons, even within the warrant period, it becomes the outside for a warranty.

- (a) Malfunctions due to erroneous applications, repairs or remodeling.
(Including the case in which the manufacturing specification differs from the application conditions.)
- (b) Malfunctions due to the falling after the purchase.
- (c) Malfunctions caused by natural disasters such as fire, earthquake, water disaster and lightning stoke, or riots or wars.
- (d) Malfunctions caused by mixing-in of foreign matters out of the piping.
- (e) Malfunctions caused by the peculiar problems due to combinations with other built in equipment.

In addition, a warranty here means the warranty of the product simple substance of our company. So the damage induced by failure of the products of our company shall be eliminated from the object of warranty.

KOFLOC Corp.

URL : <http://www.kofloc.co.jp>