



**Mass Flow Meter**

**HFM-200series**

**Mass Flow Controller**

**HFC-202series**

**KOFLOC Corp.**

The Kofloc HFM-200series mass flow meters and the HFC-202 series controller are designed to accurately measure and control mass flow over the range of 10scm to 30slm. These instruments are intrinsically linear and have an accuracy of better than  $\pm 1\%$ F.S. (full scale) .

Kofloc mass flow instruments do not require any periodic maintenance under normal operating conditions with clean gases. No damage will occur from the use of moderate overpressures (~500psi/3.45Mpa) or overflows. Instruments are normally calibrated with the appropriate standard calibration gas (nitrogen) then a correction factor is used to adjust the output for the intended gas. Calibrations for other gases, such as oxygen, helium and argon, are available upon special order.

## 1. Specifications

Accuracy	±1%full scale (F.S.)
Repeatable	±0.05% of F.S.
Maximum pressure	500psi [6.9Mpa]
Maximum pressure (with high pressure option)	1000 psig (proof tested to 1500 psig) [10.3Mpa]
Pressure coefficient	< -0.0067% of reading/psi (N <sub>2</sub> )
Operating temperature	0-60°C in non-condensing environment
Temperature coefficient (ZERO)	Maxim ±0.035%FS/°C (0-60°C)
Temperature coefficient (SPAN)	Maxim ±0.05%RDG/°C (15-50°C)
Leak integrity	< 1x10 <sup>-9</sup> std.cc/s.
Standard output	0-5VDC (load min 2k Ohms)
Optional output	4-20mA. (load < 600 Ohms)
Power requirements	± (15) VDC@55mA (meters) ± (15) VDC@150mA (controller) Class 2 power 150VA max
Wetted materials	316 SS, Viton® , 82/18 Au/Ni braze, trace silver solder, Kalrez® (controller only)
Weight	HFM-200 ; 1.8lb (0.82kg) HFM-202 ; 1.8lb (0.82kg)
Electrical connector	15pin subminiature“D”
Fitting options	HFM-200/HFC-202 ; 1/4“Swagelok®

## 2. Optional 4-20mA Current Output

An option to the standard 0-5VDC output is the 4-20mA current output that is proportional to flow. The 4-20mA signal is produced from the 0-5VDC output of the flow meter. The current loop output is useful for remote applications where pickup noise could substantially affect the stability of the voltage output.

The current loop signal replaces the voltage output on pin6 of the “D” connector. The current loop may be returned to either the power supply ground or the +15VDC connection on the power supply. If the current loop is returned to the supply ground, the load must be between 0 and 600  $\Omega$ .

## 3. Installation and Operation

---

### Quick Start

1. Insure from circuit mechanical connection are leak free.
  2. Insure electrical connections are correct (see label) .
  3. Power up. (allow 30 minutes to 1 hour warm-up for best accuracy.)
  4. Note the flow signal decays toward zero.
  5. Run ~20% flow (~1VDC) through instrument for 5 minutes.
  6. Insure zero flow ; wait 2 minutes, then zero the instrument.
  7. Instrument is ready for operation.
- 

## 4. Power Requirements

The HFM-200 requires +15VDC  $\pm$  30mA. The HFC-202 requires  $\pm$  15VDC +60mA,-185mA for proper operation. The supply voltage should be sufficiently regulated to no more than 50mV ripple. The supply voltage can vary from 14.0 to 16.0VDC.

Surge suppressors are recommended to prevent power spikes reaching the instrument.

## 5. Output Signal

The standard output of the flow meter is a 0-5VDC signal proportional to the flow rate. In the Kofloc power supply the output is routed to the display, and is also available at the terminal on the rear panel. If a Kofloc supply is not used, the output is available on pin 6 of the “D” connector. It is recommended that the load resistance be no less than  $2k\Omega$ . If the optional 4-20mA output is used, the load impedance must be selected in accordance with Section 1.2.

## 6. Mechanical Connection

The flow meter may be mounted in any position as long as the direction of gas flow through the instrument follows the arrow marked on the bottom of the flow meter case label. The preferred orientation is with the inlet and outlet fittings in a horizontal plane (if operating with a dense gas or at high pressures the instrument must be installed horizontally). When mounted in a different orientation the instrument should be re-zeroed at zero flow with the system pressurized to the expected operating pressure.

The smallest of the internal passageways in the HFM-200/HFC-202 series is the diameter of the sensor tube, which is 0.0125” (0.31 mm), so the instrument requires adequate filtering of the gas supply to prevent blockage or clogging of the tube.

The pressure regulator and the plumbing upstream must be of sufficient size to minimize changes in the upstream pressure. When switching from full flow to zero flow, the inlet pressure of instrument should rise to no more than 30% above the inlet pressure at full flow. In general, high capacity regulators and large internal diameter plumbing help to make the system more stable. The pressure drop between the regulator and the instrument due to line resistance should be minimized.

There are two UNF8-32 threaded holes, located on the bottom of the base that can be used to secure it to a mounting bracket, if desired. Other holes for special mounting can be added to the end cap as desired.

The standard inlet and outlet fittings for the 200/202 are 0.25” and 0.125” Swagelok (optional VCR or VCO fittings). The O-rings for the end cap and the sensor are Viton (optional Kalrez or Neoprene). It is suggested that all connections be checked for leaks after installation. This can be done by pressurizing the instrument (do not exceed 500psig unless the flow meter is specifically rated for higher pressures) and applying a diluted soap solution to the flow connections.

## 7. Electrical Connections

Figure 2.1 shows the schematic layout for connecting the instrument to an appropriate power supply.

If a power supply from Kofloc Instruments is used with a  $\pm 15\text{VDC}$  version of the HFM-200/HFC-202, installation consists of connecting the HFM-200/HFC-202 series cable from the “D” connector of the power supply to the “D” connector of the flow meter / controller.

If a different power supply is used, follow the instructions below when connecting the flow meter and refer to either table 2.2 for the applicable pin-out. The power supply used must be bipolar and capable of providing  $\pm 15\text{VDC}$  at  $\pm 30\text{mA}$  for flow meter applications and  $\pm 15\text{VDC}$  at  $+60\text{mA}$ ,  $-185\text{mA}$  for controllers. These voltages must be referenced to a common ground. One of the “common” pins must be connected to the AC ground locally. The cable shield (if available) should be connected to AC ground at either the power supply end, or the instrument end of the cable, not to both. Pin6 is the output signal from the flow meter. The standard output will be 0 to 5VDC, where 5VDC is 100% of the rated or full scale flow. The command (set point) input should be a 0-5VDC signal (or 4-20mA if configured as such) ,and must be free of spikes or other electrical noise, as these would generate false flow commands that the controller would attempt to follow. The command signal should be referenced to signal common.

A valve override command is available to the flow controller. Connect the center pin of a single pole, three-position switch (center off) to the override pin. Connect +15VDC to one end of the three position switch, and -15VDC to the other end. The valve will be forced full open when +15VDC is supplied to the override pin, and full closed when -15VDC is applied. When there is no connection to the pin (the three-position switch is centered) the valve will be in auto control, and will obey the 0-5VDC commands supplied to command (set-point) input.

Connecting the HFM-200/HFC-202 series flow meters with anything other the prescribed cables and power supplies discussed above, can severely damage the instrument and void the warranty.

±15VOLT 200 SERIES PINOUT DIAGRAM

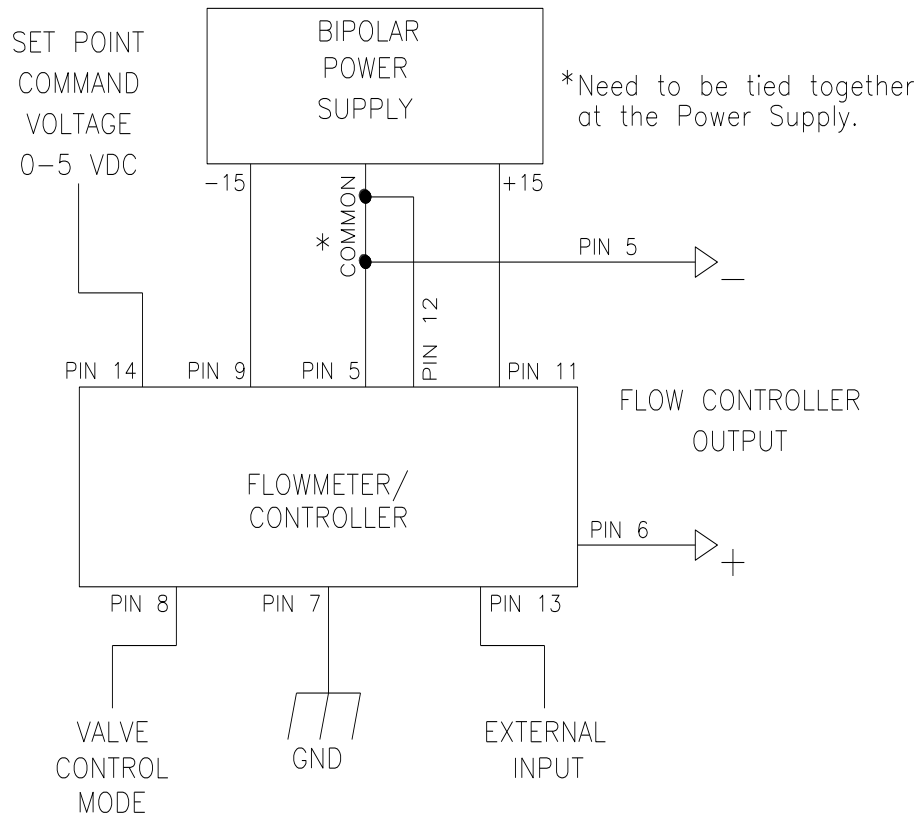

Figure 2.1

Table 2.2

PINOOTS	
PIN #	
1	Do Not Use
2	Do Not Use
3	Do Not Use
4	Do Not Use
5	Signal Common
6	Signal Output 0-5 VDC (4-20mA)
7	Case Ground
8	Control Valve Over-ride
9	-15 VDC
10	Do Not Use
11	+15 VDC
12	Valve Return
13	External Input
14	Set Point 0-5 VDC (4-20mA)
15	Do Not Use

## 8. Operating

### 8.1 Operating Conditions

For proper operation, the combination of ambient temperature must be such that the flow meter temperature remains between 0 and 60°C. The most accurate measurement of flow will be obtained if the flow meter is zeroed at operating temperature as temperature shifts result in some zero offset. The HFM-201/HFC-203 series is intended for use in non-condensing environments only. Condensate or any other liquids which enter the flow meter may destroy its electronic components.

### 8.2. Zero Check

Turn the power supply on if not already energized. Allow for a 1hour warm-up. Stop all flow through the instrument and wait 2 minutes. **Caution** : Do not assume that all metering valves completely shut off the flow. Even a slight leakage will cause an indication on the meter and an apparent zero shift. For the standard 0-5VDC output, adjust the zero potentiometer located on the lower inlet side of the flow meter until the meter indicates zero. For the optional 4-20mA output, adjust the zero potentiometer so that the meter indicates slightly more than 4mA, i.e. 4.03 to 4.05mA. This slight positive adjustment ensures that the 4-20mA current loop transmitter is not in the cut-off region. The error induced by this adjustment is approximately 0.3% of full scale. This zero should be checked periodically during normal operation. Zero adjustment is required if there is a change in ambient temperature, or vertical orientation of the flow orientation of the flow meter / controller.

### 8.3 Blending of Gases

In the blending of two gases, it is possible to maintain a fixed ratio of one gas to another. In this case, the output of one flow controller is used as the reference voltage for set point potentiometer of a second flow controller. The set point potentiometer then provides a control signal that is proportional to the output signal of the first flow controller. The set point potentiometer then provides a control signal that is proportional to the output signal of the first flow controller, and hence controls the flow rate of the second gas as a percentage of the flow rate of the first gas.

**EXAMPLE** : Flow controller A has 0-100slpm range with a 5.00V output at full scale. Flow controller B has 0-10slpm range with a 5.00V output at full scale. If flow controller A is set at 80slpm, its output voltage would be 4.00V ( $80\text{slpm}/100\text{slpm} \times 5.00\text{V} = 4.00\text{V}$ ). If the output signal from flow controller A is connected to the command potentiometer of flow controller B, it then becomes a variable reference voltage for flow controller B proportional

to the flow rate of flow controller A.

If the set point potentiometer of flow controller B is set at 50% of full scale, and the reference voltage from flow controller A is 4.00, then the command signal going to flow controller B would be 2.00V ( $4.00\text{V} \times 50.0\% = 2.00\text{V}$ ). The flow of gas through flow controller B is then controlled at 4slpm ( $2.00\text{V} / 5.00\text{V} \times 10\text{slpm} = 4\text{slpm}$ ).

The ratio of the gases is 20 : 1 (80slpm/4slpm). The % mixture of gas A is 95.2 (80slpm/84slpm) and the % mixture of gas B is 4.8% (4slpm/84slpm).

Should the flow of flow controller A drop to 3.9slpm, hence maintaining the same ratio of the mixture. ( $78\text{slpm} / 100\text{slpm} \times 5\text{V} = 3.90\text{V}$  ;  $3.90\text{V} \times 50\% = 1.95\text{V}$  ;  $1.95\text{V} / 5.00\text{V} \times 10\text{slpm} = 3.9\text{slpm}$  ;  $78\text{slpm} : 3.9\text{slpm} = 20 : 1$ )

## 8.4. Overall Function Description

The HFM-201/HFC-203 series consists of a sensor, base, shunt, control valve. The sensor is configured to measure gas flow rate from 10-500slm, depending on the customers desired overall flow rate. The shunt divides the overall gas flow such that the flow through the sensor is a precise percentage of the flow through the shunt. The flow through both the sensor and shunt is laminar. The control valve adjusts the flow so that the sensors measurement matches the set-point input. The circuit board amplifies the sensor output from the two RTD's (Resistive Temperature Detectors) and provides an analog output of either 0-5VDC or 4-20mA.

## 8.5. Gas Correction Factors

Most Kofloc flow meters and controllers are calibrated using nitrogen. The correction factors published by applied to these instruments. To apply the GCF's (Gas Conversion Factors), simply multiply the gas flow reading times the GCF for the process gas in use. For example, to calculate the actual flow of argon passing through a nitrogen-calibrated meter that reads 20sccm, multiply the reading times the GCF for argon.

$$20.000 \times 1.3978 = 27.956$$

That is, you set the meter to read 14.308sccm.

## 8.6. Outside Drawing

### Model HFM-200

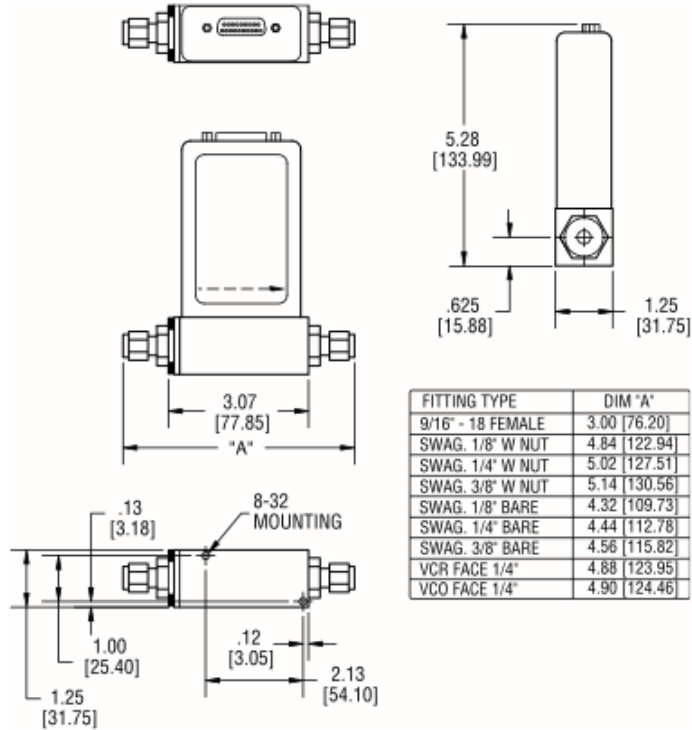

### Model HFC-202

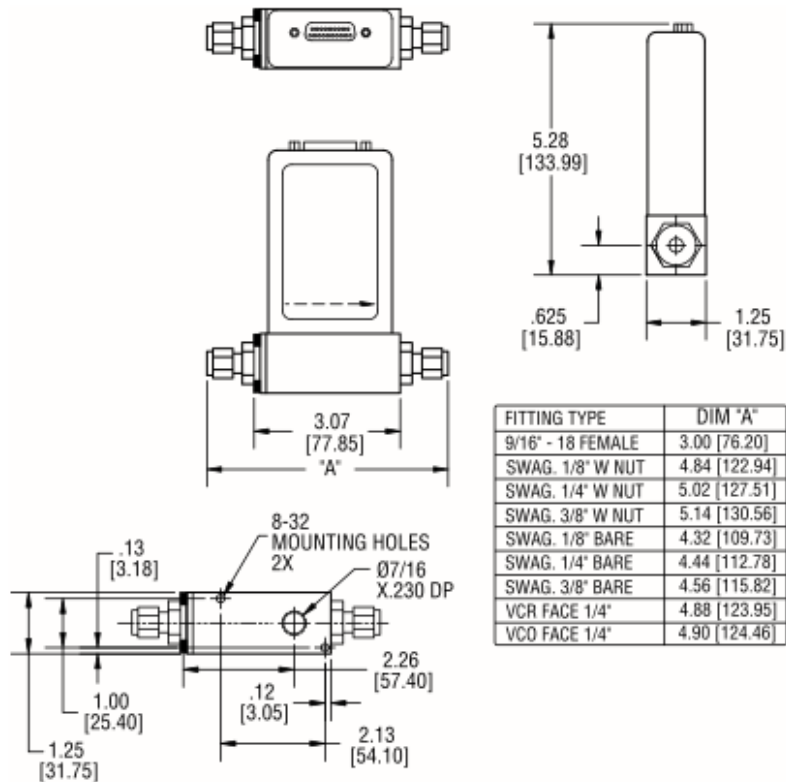

## 9. Product Warranty

### 9.1 Coverage

The warrant period shall be one year after the shipment. If the failure of the purchased product arises from our fault, the product will be repaired at no charge. Only the body and our products are covered and no damage caused by the failure will be compensated.

### 9.2 Uncovered items

In the following cases, repair will be charged even in the warranty period:

- Failure due to improper use, or unauthorized repair or remodeling.
- Failure due to fall etc. after purchase.
- Failure due to acts of providence including fire, earthquake, flood, stroke of lightning etc.
- Failure due to foreign body from piping.
- Failure due to problems that arise from combination with built-in equipment.

### 9.3 Disclaimer

The warranty stated above applies only to the product simple substance. So the damage induced by failure of the products of our company shall be eliminated from the object of warranty.

**KOFLOC Corp.**

URL : <http://www.kofloc.co.jp>