



Mass Flow Meter with indicator

MODEL 3810DSII

Instruction Manual

KOFLOC Corp.

Please read this manual thoroughly prior to installing and using the product. This way it is possible to ensure the performance and safety of the product and prevent possible accidents and damage to the product due to incorrect use.

When the product has failed or is considered to require readjustment, please contact our sales office or the dealer which you purchased the product from. Our experienced technical staff will give you appropriate advice. Please follow the instructions given.

Please note that if you repair/modify the product yourself, not only serious accidents may occur, but our warranty will become void.

The contents of the manual are subject to change without notice for improvement. Prior to shipment, every care has been taken in preparing this manual not to mention the product itself, but if you notice any imperfections, errors or omission, please contact our sales office or the dealer.

<< Prior to use >> and << Precautions for use >>

Various alert symbols and signal words are used in this manual and attached to the product to ensure correct use of the product and to prevent possible personal injury or loss of life and property damage. The symbols and meanings of the signal words are as follows:



DANGER

Ignoring this symbol and handling the product incorrectly will immediately result in loss of life or serious injury.



WARNING

Ignoring this symbol and handling the product incorrectly may result in loss of life or serious injury.



CAUTION

Ignoring this symbol and handling the product incorrectly may result in personal injury or damage to property.

Table of Contents

1. Foreword	3
2. Precautions for Handling	3
3. Overview	4
4. Specifications	6
5. Nomenclature	7
6. Installation	8
7. Operation	11
8. Troubleshooting	23
9. Warranty	25

1. Foreword

Thank you for your selection of the mass flow meter MODEL3810DS II. Prior to using your new equipment, please read this manual thoroughly to ensure it is used in a safe manner.

2. Precautions for Handling

2-1 Checking the ID plate

All the products have been assembled and adjusted one by one and the gas to use, flow rate and other data are shown on the ID plate attached to the back of the case. Check the ID plate and make sure these specifications meet your order.

Check items:

① Model

② Flow rate

SCCM = ml/min at 0°C : 1 atm (101.3kPa)

SLM = l/min at 0°C : 1 atm (101.3kPa)

NCCM = ml/min at 20°C : 1 atm (101.3kPa)

NLM = l/min at 20°C : 1 atm (101.3kPa)

*The normal state for the units of flow rate is as a rule 0°C and 1 atm. However, in order to meet the customer's request that the normal state be 20°C and 1 atm, KOFLOC indicates the units of flow rate together with the calibrating temperature and atmosphere.

Ex.: SLM(0°C, 1 atm) 0°C and 1 atm to be normal state

SLM(20°C, 1 atm) 20°C and 1 atm to be normal state

③ Name of fluid

④ Presence of the serial No.

2-2 Precautions for transportation

Wherever possible, transport the product to the installation site in the condition received from KOFLOC in order to prevent damage due to accidents during transportation.

2-3 Precautions for storage

If the product is not put in use for a long time after it was received, unexpected troubles may occur. When it is expected that the product will be kept in storage for a long time, take the following precautions:

- 1) Store the product in the package in which it was received from KOFLOC, wherever possible.
- 2) Store the product in a place described below:
 - ① A place free of rain and water.
 - ② A place free of vibration and impact.
 - ③ A place of normal temperature and normal humidity (around 25°C, 65%).
 - ④ A place free of dust.
 - ⑤ A place free of corrosive gases.
 - ⑥ A place free of a strong electric/magnetic field.

- 3) To store the product that has been used, purge with clean air or N₂ so that measuring gas will not remain in the flow meter.

Cover the inlet and outlet of measuring gas with caps to prevent intrusion of dust and dirt.

3. Overview

MODEL 3810DS II is a mass flow meter equipped with an indicator that employs a proven flow sensor. It has a function to indicate the integrated flow rate, in addition to the existing instantaneous flow rate indication.

As with the conventional model 3810DS, a type with a flow sensor and precision needle valve in one unit is also available.

- The employment of a precision needle valve enables minute flow control and monitoring.
- Flow monitoring alarm 2 points output. (2 points each for any flow rate value: 1 point only when integrating pulse output is used.)
- Instantaneous flow rate : analog output. (Voltage 1 – 5 V or current 4 – 20 mA), integrated flow rate : pulse output installed.
- Compact and light weight.
- The flow meter is equipped with an indicator and can start measurement of flow rates as soon as a 24 VDC power supply is connected.
(“Mass flow” enables direct reading of flow rates without a need of troublesome flow rate compensation calculation by temperature/pressure.)

3-1 Principle of operation

The flow detect sensor is designed with heating wire (resistance wire) wound around the outside of 2 point of the metallic capillary.

When a gas flows through the capillary, it takes heat from the resistance wire in the upstream to cause its temperature to drop. The heat in the upstream is transferred to the downstream, causing a deviation in the resistance value. A difference in temperature in these two places is proportional to the flow rate of gas. The difference in the resistance value caused by this temperature difference is converted to an electric signal to indicate a flow rate.

The installation of a bypass capillary to bypass the flow to the sensor pipe restricts the flow of gas to the sensor to enable the use in a wide range of flow rates.

The detected flow rate is indicated on the indicator and output as an electric signal from the terminals.

CAUTION: Do not use the meter for measurement and various control by use of measured values by allowing a flow exceeding the full scale (specification). The flow exceeding the full scale will cause a saturated inversion phenomenon, which may cause a problem in measuring flow rates.

* Saturated inversion phenomenon

When an amount exceeding the full scale is allowed to flow to a heat sensor, the amount of preheating of the sensor heater will be exceeded at a certain flow point, causing a saturated phenomenon. If a much larger amount is let flow further, an inversion phenomenon occurs that the flow rate indicated value decreases in inverse proportion to the flow rate.

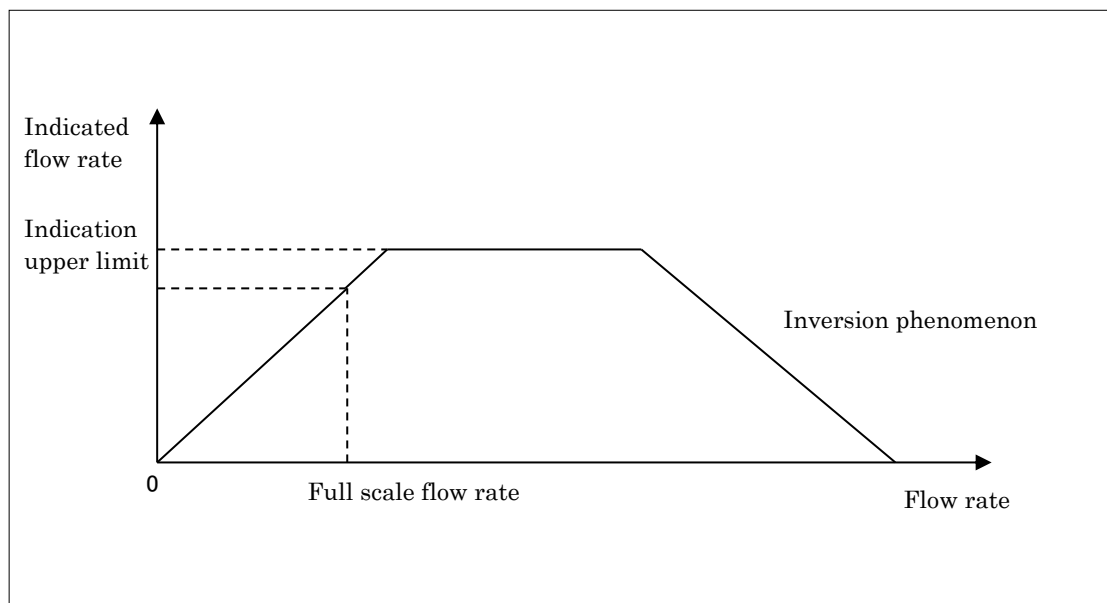

Saturated inversion phenomenon

CAUTION: When a gas not listed in the specifications is let flow or when the thermal mass flow meter calibrated with one type of gas is used for other gases, the indicated value and the actual flow rate are different.

For example, if He is let flow to the meter that has been calibrated with N₂, the actual flow rate is larger than the indicated flow rate by approx. 1.43 times.

Please keep this fact in mind and when you let a gas not listed in the specificaitons flow, please contact us for conversin factor values used for converting indicated flow rates into actual flow rates.

4. Specifications

3810DS II - 0 / V - I / V		
Flow range (N2 conversion)	F.S.10SCCM - 20SLM	F.S.30 - 100SLM
Accuracy	$\pm 2\%$ F.S. (25°C normal)	$\pm 3\%$ F.S. (25°C normal)
Operating temperature	0 - 50°C	
Temp. change effect	$\pm 0.20\%$ F.S. / °C (15 - 35°C)	
Operating humidity	30 - 80%RH (no condensation)	
Operating pressure range* ¹	0.0 - 0.5MPa (G)	
Pressure resistance	1.0MPa (G)	
Joint	Rc1/4	
Materials of parts in contact with gases	SUS303, SUS304, SUS316L, Teflon, Viton	
Required power	24 VDC ($\pm 5\%$)	
Max. power consumption	Approx. 3VA	
Data backup	Holding of set data, etc.	
Flow rate indication	Indicator	4-digit 7-segment LED (Zero blanking)
	Instantaneous flow rate indication update cycle	0.4s, 0.8s (selectable)
	Low cut function	Indication of a value below 1% F.S. settable to "0"
	Indication range	When the low cut function is not used; from approx. -10% F.S. to approx. 110% F.S. (indication limiter flashing)
	Integrated flow rate indication range * ²	8-digit indication (Max. 99,999,999, indication limiter flashing) The units of indication are the same as the instantaneous flow rate.
External output	Number of outputs	2 points (Each output selected and set to instantaneous flow rate upper limit, lower limit, upper/lower limit or integrated flow rate reach. 1 point may be integrating pulse.) Inversion of outputs is possible.
	Output judgment	Output after comparison judgment held for 1.6 sec.
	Output timing	Synchronized with indication sampling
	Output method	NPN open collector (Max. rating: 30 VDC, 50 mA)
	Integrating pulse output rate	10%F.S. / pulse, pulse width: approx. 50ms
	Alarm indication	LED lamps (AL1, AL2) turning on
	Analog output * ³	4 - 20mA (250 Ω or below) or 1 - 5V (10k Ω or over)
Others	Zero offset function, CE compliance	
Weight	Approx. 400g	
Needle valve part (3810DS II - V - I / V)		
Flow adjust knob turning	Approx. 12 turns	
Materials of parts in contact with gases	SUS303, SUS316, Teflon, Viton	

*1. The operating pressure does not guarantee the pressure gives the flow rate in the specifications.

*2. The indication of integrated flow rates is for reference. It is held when the power is turned off.

*3. The analog output has been set to your order.

5. Nomenclature

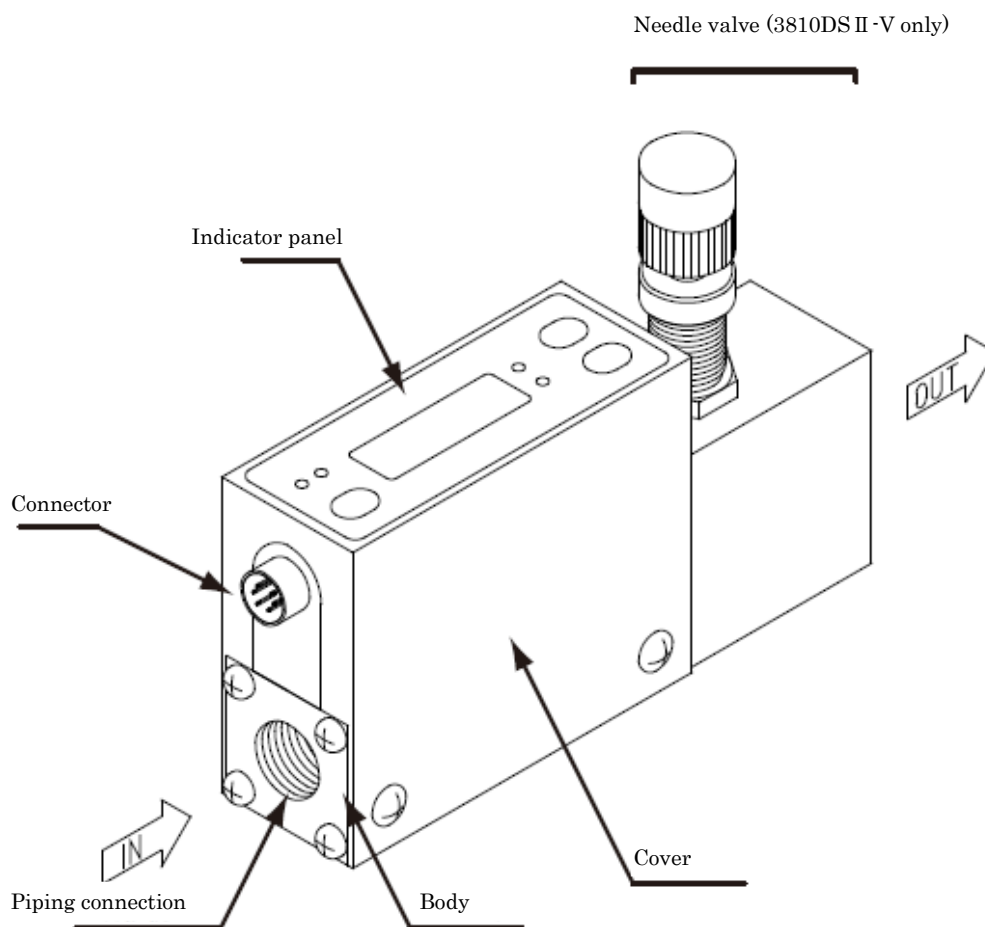

Wiring

Product side connector: Hirose Electric HR10A - 7R - 6P

Matching connector: Hirose Electric HR10A - 7P - 6S (AWG30 - 26)

Signal table

Pin No.	Signal Name	Description
1	+24V	Power input +24 VDC
2	P_COM	Power input, analog output COM
3	AL1	Alarm output 1 or integrating pulse output
4	AL2	Alarm output 2
5	AL_COM	Alarm output COM
6	A_OUT	Analog output

6. Installation

6-1 Installation place

- ① This equipment is designed for indoor use.
Never install the equipment in a place where it is likely to be wetted by water or rain. The equipment may fail. Install the equipment in a place where sufficient ventilation is provided and changes in temperature and humidity are minimal.
- ② Install the equipment in a place free of vibration and impact.
- ③ Do not use the equipment under direct sunlight or at high temperature/humidity.
- ④ Install the equipment in a place free of dust.
- ⑤ Install the equipment in a place free of corrosive gases.
- ⑥ Install the equipment in a place free of a strong electric/magnetic field.
- ⑦ After installation, be sure to conduct leak test on piping.
- ⑧ Install the equipment in a place where the operating temperature is 15 to 35°C.

The use of the equipment in a condition deviating from the conditions described in the specifications is a cause of failure.



CAUTION

When installing the mass flow meter, noise generating sources in the vicinity of installation, environment filled with moisture and dust and very hot, corrosive gas ambient must be avoided. Such conditions are causes of serious failure.

6-2 Installation method

Install the meter using the threaded holes (M3) on the bottom of the body.

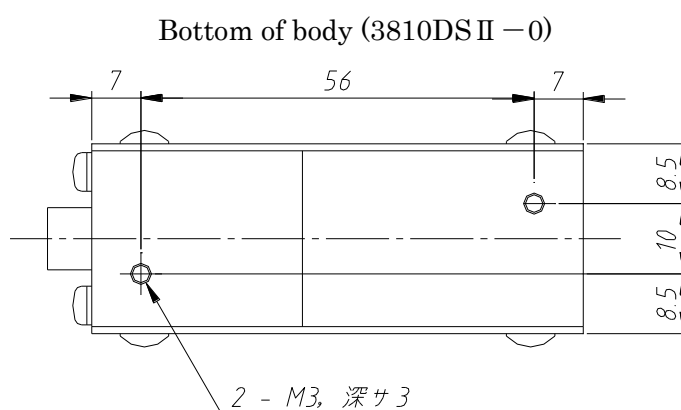

6-3 Installation posture

The basic installation posture is horizontal. If the meter is to be installed vertically, conduct sufficient warmup run and zero point adjustment.

Determine the inlet and outlet of gas piping as indicated by the arrows on the indicator panel.

6-4 Piping and filter

When using commercially available pipes and joints for piping, be sure that they have been cleaned completely or they are clean.

Install a line filter (finer than 100 μm) on the inlet side of gas. A standard filter has been installed on the inlet side of the meter, but if a large amount of impurities sticks to it, gas will not flow smoothly, disabling accurate measurement and control.

In particular, when using air from a compressor or blower, a large amount of oil mist and water droplets may be produced. Install an oil filter and water-removing filter before the meter.



CAUTION

Never wash the piping system after the mass flow meter has been installed. Such a practice may cause serious failure.



WARNING

Check to see if the connections of gas piping are not leaking. If such a check is omitted and unsafe gas is used, serious accidents may occur.



CAUTION

Give careful consideration to piping after the meter also to ensure that water droplets condensed within the piping will not enter the equipment due to counterflow.

6-5 Wiring

Connect wiring referring to the diagram below.

Use connectors dedicated for connection. Firmly insert connectors to the designated places.

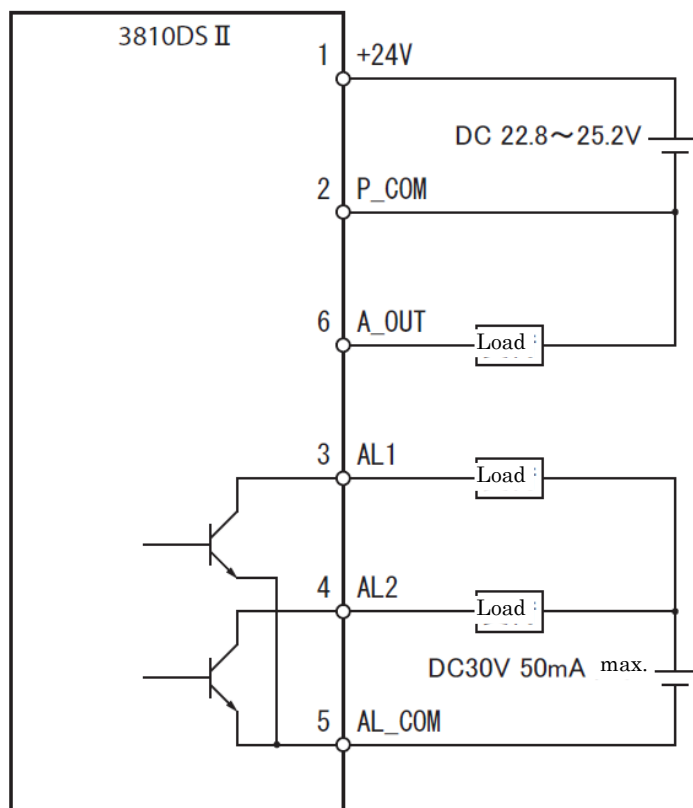

Wiring

Product side connector: Hirose Electric HR10A - 7R - 6P

Matching connector: Hirose Electric HR10A - 7P - 6S (AWG30 - 26)

Signal table

Pin No.	Signal Name	Description
1	+24V	Power input +24 VDC
2	P_COM	Power input, analog output COM
3	AL1	Alarm output 1 or integrating pulse output
4	AL2	Alarm output 2
5	AL_COM	Alarm output COM
6	A_OUT	Analog output

7. Operation

7-1 Warming-up

Warm up the equipment at least 30 minutes after it was powered on.

7-2 Operating procedure

- Indicator panel

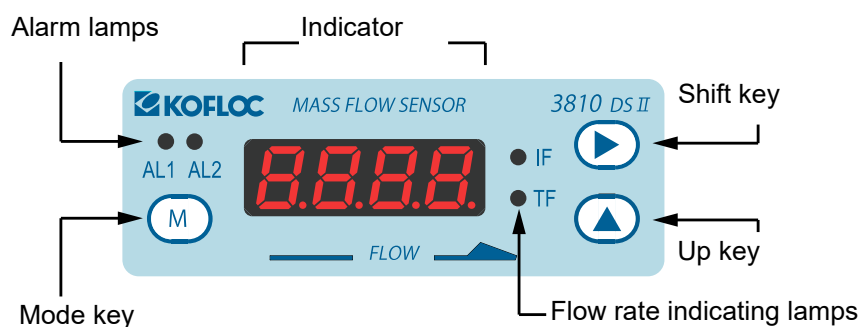

- Indicator

Indicates an instantaneous flow rate or integrated flow rate. When lower 4 digits of the integrated flow rate are indicated, the decimal point is shown.

The decimal point is not shown for upper 4 digits.

During setting, the mode No. or set value is shown here.

- Alarm lamps

When the alarm output 1 is on, “AL1” lights and when the alarm output 2 is on, “AL2” lights.

- Flow rate indicating lamps

When an instantaneous flow rate is indicated, “IF” lights on and when an integrated flow rate is indicated, “TF” lights on.

- Mode key [M]

Measurement: When this key is pressed and held for approx. 2 seconds, the meter will enter the setting mode.

Setting: Switches over the modes.

When the key is pressed and held for approx. 2 seconds, the set value will be registered and the flow rate will be indicated.

CAUTION: If the power is turned off during setting, the set value will not be registered.

- Shift key [>]

Measurement: Switches over the flow rates to indicate.

Indication is switched over in the order of instantaneous flow rate → integrated flow rate (upper 4 digits) → integrated flow rate (lower 4 digits) → instantaneous flow rate.

The integrated flow rate (upper 4 digits) will not be indicated when the integrated flow rate value has not reached the upper 4 digits.

Setting: Moves the flashing digit to right.

• Up key [^]

Measurement: When an instantaneous flow rate is being indicated, pressing and holding this key for approx. 2 seconds sets up the zero adjustment mode.

When an integrated flow rate is being indicated, pressing and holding this key for approx. 2 seconds sets up the integrated flow rate reset mode.

Setting: Increments the value of the flashing digit. (0 after 9)

CAUTION: This meter has been adjusted in the flow rate in the factory and adjustment data has been stored in an F-RAM. Please keep in mind that if several keys on the indicator panel are pressed and held simultaneously when turning on the power, the indicator shows the mode where the stored data will be rewritten. When the meter has entered this mode, turn off the power. If rewrite has not been enabled yet, the data may be recovered. If the data has been rewritten, it is necessary to correct the data.

7-3 Zero adjustment (Zero offset)

With an instantaneous flow rate being indicated, stop the flow of gas completely. In this state, press and hold the up key [^] for approx. 2 seconds. Then the indicator will show Zero. Next, pressing the mode key [M] once shows AJST. When AJST is being shown, pressing the shift key [>] causes AJST to flash. When the key is pressed and held for approx. 2 seconds, “0” will be shown and the zero adjustment will be completed.

(If flickering of a figure near 0 is annoying, select the low cut function. The indication of a figure below 1% F.S. is cut.)

To reset the zero offset function, while ZEr0 is being shown, press the mode key [M] twice to show rSET. Press and hold the shift key [>] for approx. 2 seconds to reset the zero offset function.

CAUTION: If the indicated value is largely different from the zero point set in the factory, the zero adjustment is not possible. In this case, please contact our sales office or the dealer.

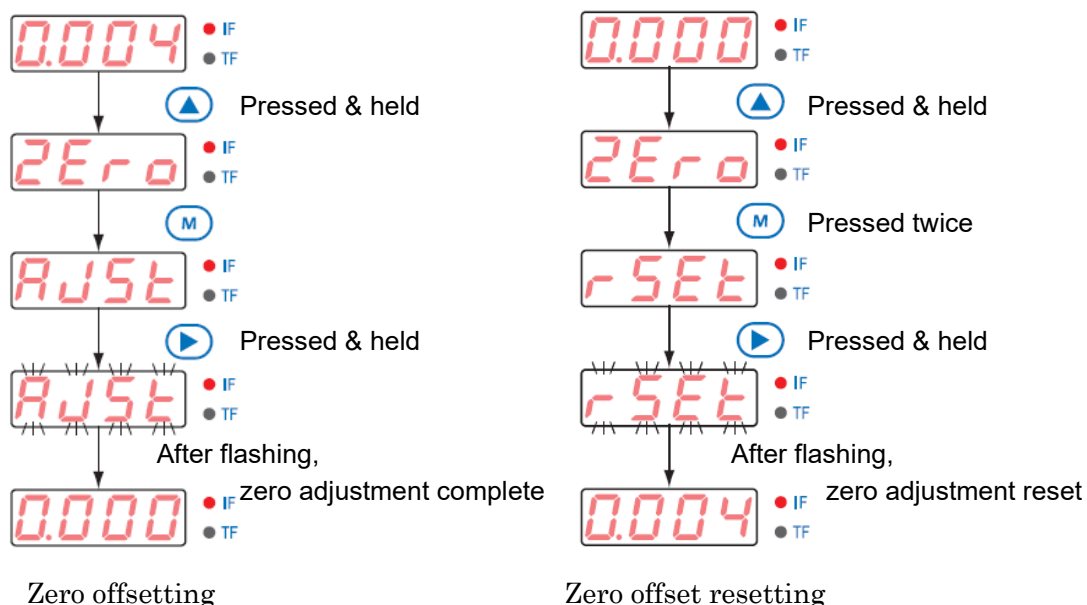

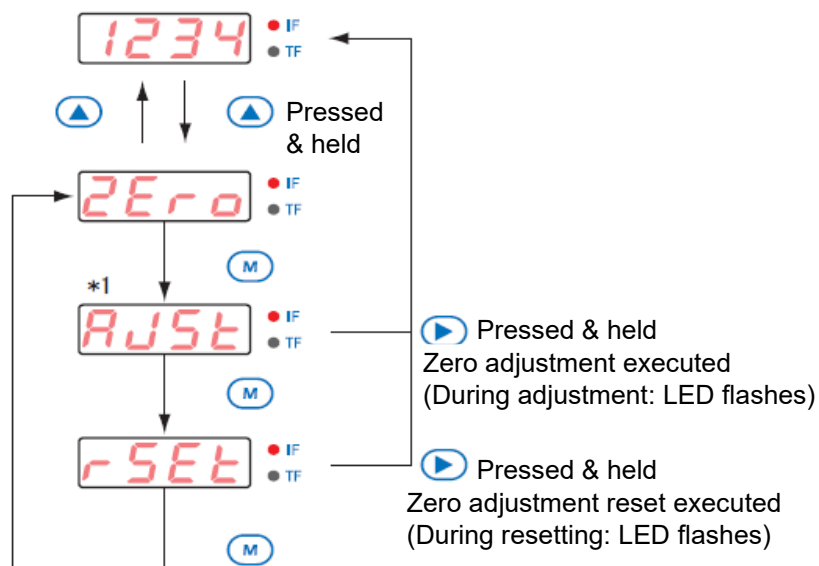

* 1. If the value deviates from zero more than $\pm 5\%$ F.S., nothing is shown and the zero adjustment cannot be executed.

Transition of modes when instantaneous flow rate is being indicated

7-4 Flow rate indication

① Switching over flow rates to indicate

Each time the shift key [$>$] on the flow rate indicator panel is pressed, indication is switched over in the order of instantaneous flow rate \rightarrow integrated flow rate (upper 4 digits) \rightarrow integrated flow rate (lower 4 digits). The integrated flow rate (upper 4 digits) will not be indicated, however, when the integrated flow rate value has not reached the upper 4 digits. When an instantaneous flow rate is being indicated, the “IF” LED lights and when an integrated flow rate is being indicated, the “TF” LED lights.

② Units of flow rate

The units of integrated flow rates are the specification units from which “time” has been removed. When the unit of the instantaneous flow rate in the specification is “SLM”, the unit of the integrated flow rate is “SL” and when the unit of the instantaneous flow rate is “SCCM”, the unit of the integrated flow rate is “Sc”.

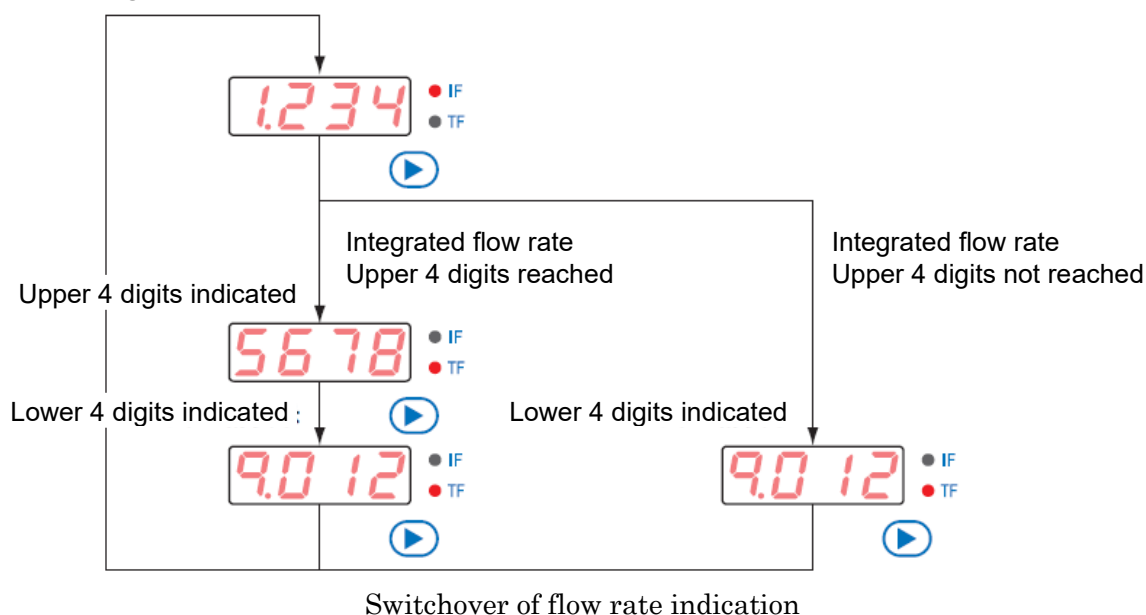

③ Integrated flow rate resetting

In the state of integrated flow rate indication setting, press and hold the up key [△] for approx. 2 seconds. Then the indicator will show [Intg]. Next, pressing the mode key [M] once shows [rSEt]. When [rSEt] is being shown, pressing and holding the shift key [>] causes [rSEt] to flash. When the key is pressed and held for approx. 2 seconds, the integrated flow rate value will be re-set.

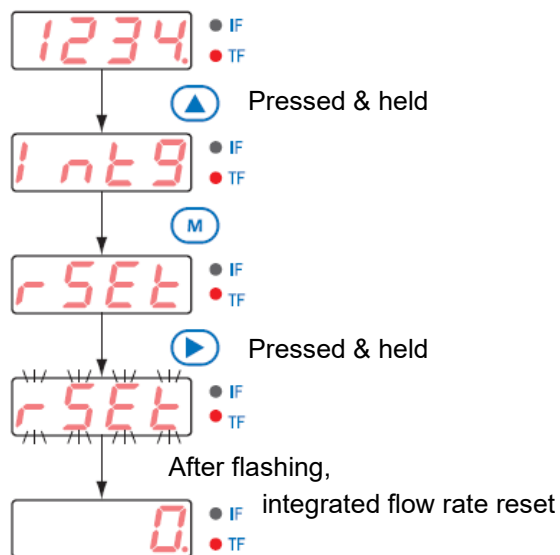

Integrated flow rate resetting

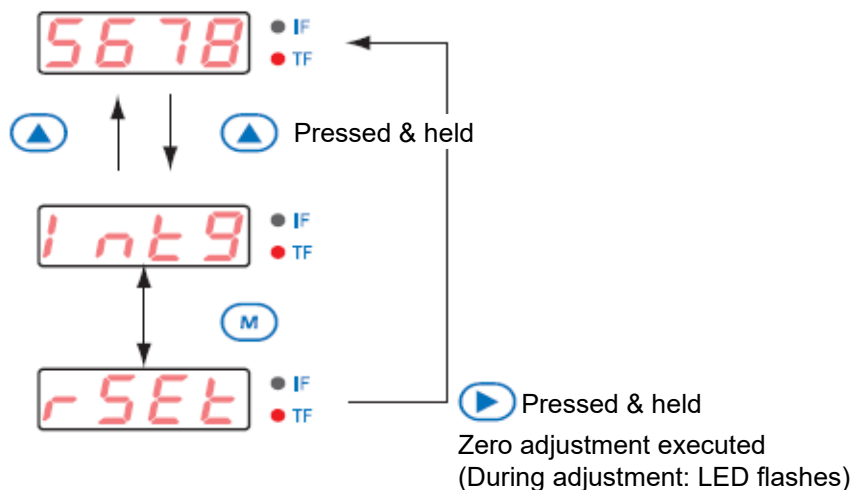

Transition of modes when integrated flow rate is being indicated

7-5 Parameter setting

When an instantaneous flow rate/integrated flow rate is being indicated, pressing and holding the mode key [M] for approx. 2 seconds sets the parameter setting mode. Each time the mode key [M] is pressed, the indication changes in the order of mode No. → set value → mode No. → set value. To change the set value, change the digits with the shift key [>] and change the figures with the up key [Δ].

After setting a parameter, pressing and holding the mode key [M] for approx. 2 seconds registers the set value and returns the mode to the flow rate indication mode.

CAUTION: After setting a parameter, if you do not return to the flow rate indication mode by pressing and holding the mode key [M], the set value **will not be registered**.

① Default values

Mode No.	Default Value				Set Item
	A	B	C	D	
ABCD	x .	x	x	x	Indication of max. value (unchangeable)
P-00	—	0	—	—	Instantaneous flow rate indication update cycle
	—	—	0	—	Low cut function selection
	—	—	—	0	Integrated flow rate hold selection
P-10		0			AL1 output selection
			0		AL1 output inversion selection
				0	AL1 instantaneous flow rate alarm output motion selection
P-11	9	9	9	9	AL1 instantaneous flow rate upper limit preset setting
P-12	0	0	0	0	AL1 instantaneous flow rate lower limit preset setting
P-13	9	9	9	9	AL1 integrated flow rate reach preset setting upper 4 digits
	9	9	9	9	AL1 integrated flow rate reach preset setting lower 4 digits
P-20		0			AL2 output selection
			0		AL2 output inversion selection
				0	AL2 instantaneous flow rate alarm output motion selection
P-21	9	9	9	9	AL2 instantaneous flow rate upper limit preset setting
P-22	0	0	0	0	AL2 instantaneous flow rate lower limit preset setting
P-23	9	9	9	9	AL2 integrated flow rate reach preset setting upper 4 digits
	9	9	9	9	AL2 integrated flow rate reach preset setting lower 4 digits

Setting mode No. and description of set values

Mode No.	Indication of max. value (Full scale)								
F-00	<table style="margin-left: auto; margin-right: auto;"> <thead> <tr> <th>A</th> <th>B</th> <th>C</th> <th>D</th> </tr> </thead> <tbody> <tr> <td style="border: 1px solid black;">1.</td> <td style="border: 1px solid black;">0</td> <td style="border: 1px solid black;">0</td> <td style="border: 1px solid black;">0</td> </tr> </tbody> </table> <p>[Max. value] The value of the full scale is indicated. Unchangeable.</p>	A	B	C	D	1.	0	0	0
A	B	C	D						
1.	0	0	0						
Mode No.	Instantaneous flow rate indication update cycle, low cut function, integrated flow rate value hold setting								
P-00	<table style="margin-left: auto; margin-right: auto;"> <thead> <tr> <th>A</th> <th>B</th> <th>C</th> <th>D</th> </tr> </thead> <tbody> <tr> <td style="border: 1px solid black;">0</td> <td style="border: 1px solid black;">0</td> <td style="border: 1px solid black;">0</td> <td></td> </tr> </tbody> </table> <p style="margin-left: 100px;"> ↘ Integrated flow rate value hold setting 0: Not used, 1: Used ↙ Low cut function selection 0: Not used, 1: Used ↖ Instantaneous flow rate indication update cycle 0: 0.4 s, 1: 0.8 s</p> <p>[Instantaneous flow rate indication update cycle] Input signals are measured during the period set here and an average value is calculated. Therefore, the indication is averaged and updated at the set cycle.</p> <p>[Low cut function selection] Select either use or nonuse of the low cut function. Used: Instantaneous flow rates below 1% F.S. are indicated as 0. Negative values are also indicated as 0. Not used: Instantaneous flow rates below 1% F.S. are indicated. Negative values are also indicated.</p> <p>[Integrated flow rate value hold setting] Select either use or nonuse of integrated flow rate value hold setting. Used: The integrated flow rate value is held after the power is turned off. The integrated flow rate value hold cycle is 1 minute. Not used: The integrated flow rate value is reset when the power is turned off.</p>	A	B	C	D	0	0	0	
A	B	C	D						
0	0	0							

Mode No.	Alarm output 1 motion function selection and output setting (OUT1)								
P-10	<div style="text-align: center; margin-bottom: 10px;"> <table border="1" style="margin: auto;"> <tr> <td style="padding: 2px 10px;">A</td> <td style="padding: 2px 10px;">B</td> <td style="padding: 2px 10px;">C</td> <td style="padding: 2px 10px;">D</td> </tr> <tr> <td style="padding: 2px 10px;">0</td> <td style="padding: 2px 10px;">0</td> <td style="padding: 2px 10px;">0</td> <td style="padding: 2px 10px;"></td> </tr> </table> </div> <div style="margin-left: 100px;"> <p>→ Alarm output motion function setting 0: Steady judgment output 1: Output non-judgment, judgment prohibit time output</p> <p>→ Output inversion setting 0: Normal output 1: Inverted output</p> <p>→ Output 1 setting 0: No 1: Instantaneous flow rate upper limit 2: Instantaneous flow rate lower limit 3: Instantaneous flow rate upper/lower limit 4: Integrated flow rate reach 5: Integrating pulse</p> </div> <hr style="border-top: 1px dashed black;"/> <p>[Alarm output] The function works according to results of comparison between the indicated value and the preset value.</p> <p>[Output setting] Set a condition for alarm output. The normal output has been set and then if the alarm output condition is set, the AL1 LED lights and the alarm output 1 is outputted. The upper limit, lower limit and upper/lower limit alarms are output when each condition is met for 1.6 seconds continuously and when each condition is not met for 1.6 seconds continuously, they are reset.</p> <p>0: No The alarm mode is not used.</p> <p>1: Instantaneous flow rate upper limit output Output when “instantaneous flow rate value \geq P-11 upper limit preset value”.</p> <p>2: Instantaneous flow rate lower limit output Output when “instantaneous flow rate value \leq P-12 lower limit preset value”.</p> <p>3: Instantaneous flow rate upper/lower limit output Output when “instantaneous flow rate value \geq P-11 upper limit preset value” or “instantaneous flow rate value \leq P-12 lower limit preset value”.</p> <p>*The alarm is constantly output when “P-11 upper limit preset value \leq P-12 lower limit preset value” is set.</p> <p>4: Integrated flow rate reach Output when “integrated flow rate value \geq P-13 upper limit preset value”.</p> <p>5: Integrating pulse Pulses of approx. 50 ms are output every 10% F.S. of the integrated flow rate value.</p>	A	B	C	D	0	0	0	
A	B	C	D						
0	0	0							

[Output inversion setting]

Set the output of alarm output 1.

0: Normal

Output by the condition set in [Output setting].

1: Inverted

Reverse motion of the above.

CAUTION: The lighting of the LED on the indicator panel will not be inverted.

[Alarm output motion function]

Select the overall motion of alarm outputs.

0: Steady judgment output

The indicated value and the preset value are always compared and the alarm is output according to the results.

1: Output non-judgment, judgment prohibit time output

Except for the following case, the indicated value and the preset value are compared and the alarm is output according to the results.

Output non-judgment: When the input voltage is below 1% F.S., the alarm output is not judged.

Judgment prohibit time: The function works after the input voltage exceeds 1% F.S. and the output judgment is prohibited for 15 seconds.

Alarm output timing chart

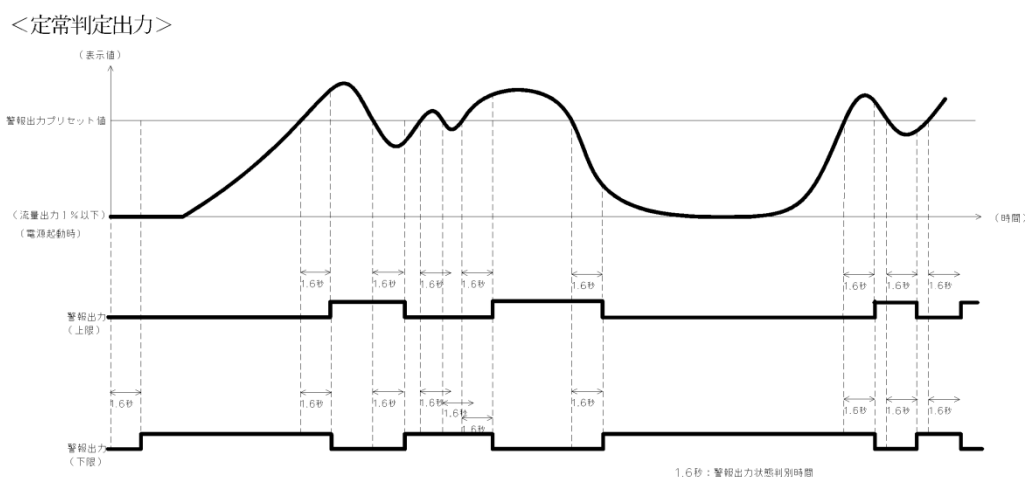

3: Instantaneous flow rate upper/lower limit
4: Integrated flow rate reach

Set this according to the description of P-10.

*"Integrating pulse" cannot be selected in output 2 setting.

Mode No.	Alarm output 2: Instantaneous flow rate upper limit preset (when instantaneous flow rate upper limit, upper/lower limit output set)																
P-21	<table style="margin-left: auto; margin-right: auto;"> <tr> <td style="padding: 0 10px;">A</td> <td style="padding: 0 10px;">B</td> <td style="padding: 0 10px;">C</td> <td style="padding: 0 10px;">D</td> </tr> <tr> <td style="text-align: center;">┌</td> <td style="text-align: center;">┌</td> <td style="text-align: center;">┌</td> <td style="text-align: center;">┌</td> </tr> <tr> <td style="text-align: center;">9</td> <td style="text-align: center;">9</td> <td style="text-align: center;">9</td> <td style="text-align: center;">9</td> </tr> <tr> <td style="text-align: center;">└</td> <td style="text-align: center;">└</td> <td style="text-align: center;">└</td> <td style="text-align: center;">└</td> </tr> </table> <p style="text-align: center;"> </p> <p style="text-align: center;">└→ Setting of output 2 preset value: 0000 – 9999</p> <p style="text-align: center;">*Output according to results of comparison with a 4-digit value.</p> <p><Caution> Not indicated depending on setting of P-20.</p>	A	B	C	D	┌	┌	┌	┌	9	9	9	9	└	└	└	└
A	B	C	D														
┌	┌	┌	┌														
9	9	9	9														
└	└	└	└														

Mode No.	Alarm output 2: Instantaneous flow rate lower limit preset (when instantaneous flow rate lower limit, upper/lower limit output set)																
P-22	<table style="margin-left: auto; margin-right: auto;"> <tr> <td style="padding: 0 10px;">A</td> <td style="padding: 0 10px;">B</td> <td style="padding: 0 10px;">C</td> <td style="padding: 0 10px;">D</td> </tr> <tr> <td style="text-align: center;">┌</td> <td style="text-align: center;">┌</td> <td style="text-align: center;">┌</td> <td style="text-align: center;">┌</td> </tr> <tr> <td style="text-align: center;">0</td> <td style="text-align: center;">0</td> <td style="text-align: center;">0</td> <td style="text-align: center;">0</td> </tr> <tr> <td style="text-align: center;">└</td> <td style="text-align: center;">└</td> <td style="text-align: center;">└</td> <td style="text-align: center;">└</td> </tr> </table> <p style="text-align: center;"> </p> <p style="text-align: center;">└→ Setting of output 2 preset value: 0000 – 9999</p> <p style="text-align: center;">*Output according to results of comparison with a 4-digit value.</p> <p><Caution> Not indicated depending on setting of P-20.</p>	A	B	C	D	┌	┌	┌	┌	0	0	0	0	└	└	└	└
A	B	C	D														
┌	┌	┌	┌														
0	0	0	0														
└	└	└	└														

Mode No.	Alarm output 2: Integrated flow rate reach preset (when integrated flow rate reach set)
P-23	<p>A B C D</p> <p>9 9 9 9 —(Upper 4 digits)</p> <p>9 9 9 9. —(Lower 4 digits)</p> <p>Setting of output 2 preset value: 0000 0000 – 9999 9999</p> <p>*The decimal point is shown in lower 4 digits. (The position of the decimal point varies depending on specification flow rates.)</p> <p>*Upper 4 digits and lower 4 digits are switched over with the shift key [>].</p> <p>*Output according to results of comparison with an 8-digit value.</p> <p><Caution> Not indicated depending on setting of P-20.</p>

Transition of the alarm output 1 mode

(In the case of alarm output 2, “1” in **P - 1X** becomes “2”.)

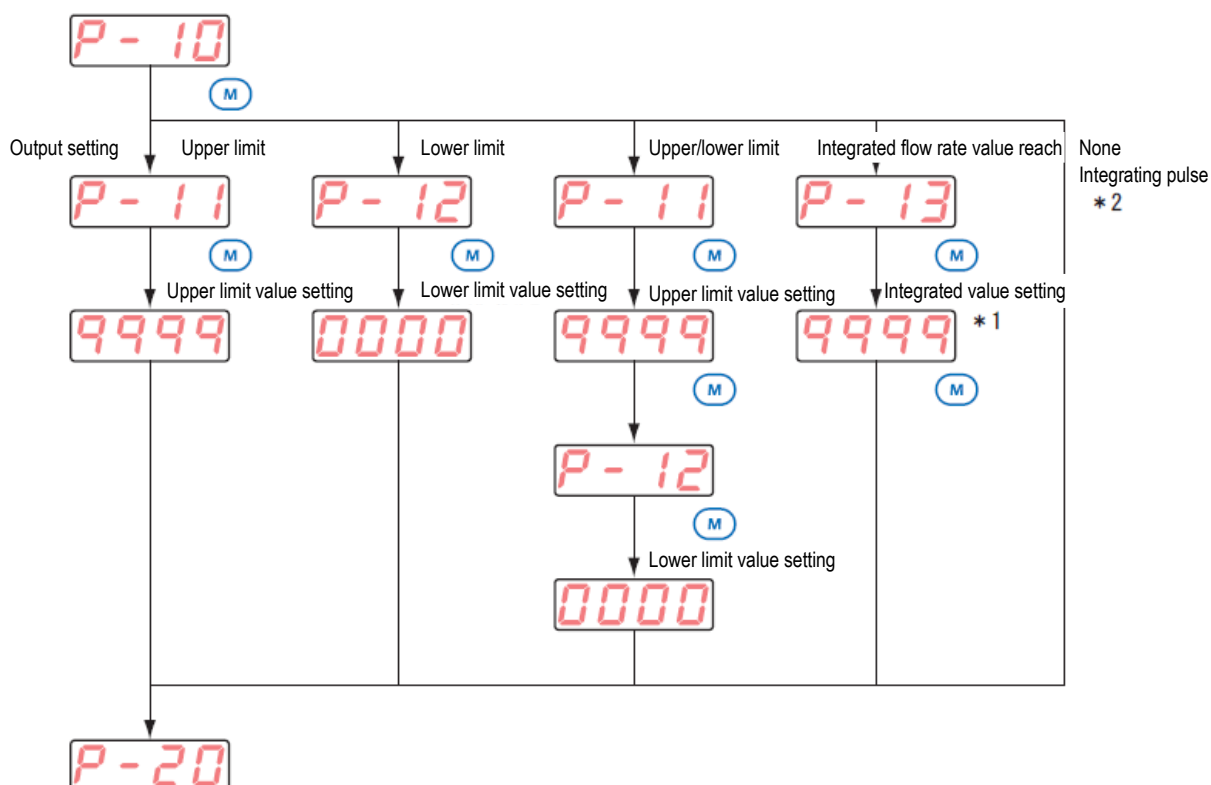

*1. Upper 4 digits and lower 4 digits can be switched over with the shift key [>]. (The decimal point is shown in lower 4 digits.)

*2. Setting of the integrating pulse is allowed only in P-10.

8. Troubleshooting

Problem	Probable Cause	Check Item and Corrective Action
1. The indicator shows nothing.	a. The power is not on.	1. Check to see if the power has been turned on.
	b. The connector has not been connected to the meter properly.	1. Connect the connector properly. Check to see if the pin numbers of wires and destinations match.
2. The indication of a flow rate remains 0.	a. Gas is not flowing.	1. Check the source pressure of the gas cylinder and check the valve to see if it is open. 2. Check to see if the solenoid valve, three-way valve, etc. in the line are operating properly. 3. Check to see if the line filter is not clogged.
	b. The outlet side piping of the mass flow meter is blocked somewhere.	1. Check the solenoid valve, three-way valve, air valve, etc.
	c. The power supply is faulty.	1. Disconnect the cable and check the voltage 24 VDC (within $\pm 5\%$) with a tester. If the correct voltage is not present, replace the power supply.
	d. The sensor tube is clogged.	1. If it is clogged, gas keeps flowing. The sensor must be replaced. Please send it to our sales office or the dealer.
3. The output will not become zero (more than 45 minutes after power on).	a. The control valve is leaking internally or externally.	1. Disconnect the pipe before of the mass flow controller and remove gas to see if the output will become zero.
	b. The zero point of the sensor has moved.	1. Conduct zero adjustment.
	c. The sensor is faulty or the electronic circuit is faulty.	1. The meter may be used after zero point adjustment, but the flow accuracy will be impaired. Please send them to our sales office or the dealer for replacement.
4. The indication of a flow rate flickers when gas is flowing.	a. The supply pressure on the inlet side is constantly instable.	1. Install a pressure regulator on the inlet side to keep the pressure constant.
	b. The connector connection is poor.	1. Check to see if the connector has been connected correctly.
	c. The power supply is faulty.	1. Disconnect the cable and check the voltage 24 VDC (within $\pm 5\%$) with a tester. If the voltage is not stable, replace the power supply.

Problem	Probable Cause	Check Item and Corrective Action
5. The flow is obviously less than the indicated flow rate.	a. The piping line is leaking.	1. Check leak from the piping line due to failure to tighten nuts, insufficient tightening or other causes by an evacuation method or leak detector liquid. Re-tighten the nut in the leaking place to stop leak.
	b. The mass flow meter itself is leaking.	1. Same as above. Note, however, when checking leak with leak detector liquid, apply it only to the joints before and after the body, but not to the inside of the cover of the body. After check, remove leak detector liquid completely.
	c. The bypass part is clogged.	1. To replace the bypass part, please send it to our sales office or the dealer.
6. The flow is obviously greater than the indicated flow rate.	a. An inversion phenomenon has occurred.	1. Be sure the flow rate is below the full scale (spec.).
	b. The sensor tube is almost clogged.	1. To replace the sensor tube, please send it to our sales office or the dealer.

* If the problem cannot be solved by the above corrective actions, please contact our sales office or the dealer.

9. Warranty

9-1 Product warranty

1. Contents of warranty

① Warranty period

The warranty period is one (1) year after ex-factory date of KOFLOC.

② Scope of warranty

If the KOFLOC product fails during the warranty period due to a cause attributable to KOFLOC, KOFLOC will, at its option and expense, provide a replacement product or repair the failed product at the KOFLOC factory.

This warranty, however, shall not cover damages due to a cause not attributable to KOFLOC, opportunity loss, lost profit, secondary disaster and accident compensation suffered by the customer and damage to other equipment and any other compensation due to failure of the KOFLOC product.

③ Out of warranty

The warranty shall not apply to the following failures even if they occur during the warranty period:

- a) Failure due to misuse or improper repair or modification. (Failure resulting from use under conditions different from the manufacturing specifications is included.)
- b) Failure due to dropping of the product after purchase.
- c) Failure due to fire, earthquake, flood, lightning or other natural disaster, or riot, war or the like.
- d) Failure due to intrusion of foreign matter from piping.
- e) Failure caused by a problem specific to a combination with other incorporated equipment.
- f) Other failures which are considered not attributable to KOFLOC.

Please be aware that the warranty shall not cover opportunity loss suffered by the customer or end user or damage to other equipment or any other damages due to failure of the KOFLOC product.

KOFLOC Corp.

URL : <http://www.kofloc.co.jp>