



Readout Unit
for
Mass Flow Meter/Controller

CR-400

Instruction Manual

KOFLOC Corp.

Table of Contents

	Page
<u>1. Foreword</u>	4
1.1 Overview	4
1.2 Specifications	4
Connector pin assignment	6
<u>2. Installation</u>	7
2.1 Upon receipt of the product	7
2.2 Installation place	7
2.3 Installation	8
External view	8
<u>3. Wiring</u>	8
3.1 Wiring to the mass flow meter/controller	8
3.2 Wiring to external equipment	9
An example of CN1 wiring	9
<u>4. Nomenclature and Description of the Functions</u>	11
<u>5. Operating Procedure</u>	13
5.1 Locked state	13
(1) Indicating the flow rate set value	13
(2) Indicating the full scale value	13
(3) Switching over the indicated flow rate values	14
5.2 Unlocked state	14
(1) Setting a flow rate value	14
(2) Setting the full scale and other parameters [Parameter setting mode]	14
(3) Setting the valve forced open control	15
(4) Setting the valve forced close control	15
(5) Switching over the flow rate setting methods	15
(6) Initializing the integrated flow rate	16
A list of major operations	16

	Page
<u>6. Parameter Setting</u>	17
<u>7. RS-485 Communication</u>	20
7.1 Basic specifications	20
7.2 Commands and responses	20
(1) Read command [Host controller → CR-400]	20
(2) Read response [CR-400 → host controller]	20
(3) Write command [Host controller → CR-400]	21
(4) Write response [CR-400 → host controller]	21
7.3 Description of the addresses	22
7.4 An example of communication	24
<u>8. Failure</u>	25
8.1 If failure is suspected	25
8.2 Warranty	26

Please read this manual thoroughly prior to installing and using the product. This way it is possible to ensure the performance and safety of the product and prevent possible accidents and damage to the product due to incorrect use.

When the product has failed or is considered to require readjustment, please contact our sales office or the dealer which you purchased the product from. Our experienced technical staff will give you appropriate advice. Please follow the instructions given.

Please note that if you repair/modify the product yourself, not only serious accidents may occur, but our warranty will become void.

The contents of the manual are subject to change without notice for improvement. Prior to shipment, every care has been taken in preparing this manual not to mention the product itself, but if you notice any imperfections, errors or omission, please contact our sales office or the dealer.

<< Prior to use >> and << Precautions for use >>

Various alert symbols and signal words are used in this manual and attached to the product to ensure correct use of the product and to prevent possible personal injury or loss of life and property damage. The symbols and meanings of the signal words are as follows:



DANGER

Ignoring this symbol and handling the product incorrectly will immediately result in loss of life or serious injury.



WARNING

Ignoring this symbol and handling the product incorrectly may result in loss of life or serious injury.



CAUTION

Ignoring this symbol and handling the product incorrectly may result in personal injury or damage to property.

1. Foreword

1.1 Overview

The readout unit CR-400, developed for incorporation into the customer's equipment and machinery, is of DIN size compact design for supplying power to KOFLOC mass flow meters/controllers (MFM/MFC) and easy connection to external equipment.

This readout unit has a flow rate setting methods (CR-400 / external equipment) switchover function, a valve forced open/close control function, a flow rate integrating function and an event output function, in addition to functions to output flow signals to and input flow rate setting signals from external equipment connected with connectors. It also enables remote operation and monitoring via RS-485 communications.

1.2 Specifications

- Model: CR-400

- Measurement

- ① Flow rate signal input voltage: Analog differential input
-0.5 – +6.0 VDC
(0V: Zero, +5.0 V: Full scale/F.S.)
- ② Input impedance: 1 M Ω min.
- ③ Flow rate setting output voltage: 0 – +5.0 VDC
(0V: Zero, +5.0 V: Full scale/F.S.)

- Display

- ① Indicating LED: 4 digits, 7-segment, red, height 14 mm
[Instantaneous flow rate 4 digits,
integrated flow rate 8 digits: upper/lower 4 digits switchover]
- ② Measurement over, etc. : Indicated by flashing
- ③ Accuracy: [Instantaneous flow rate] $\pm 0.1\%$ F.S. ± 1 digit
[Integrated flow rate] Calculated reference value
- ④ Update cycle: [Instantaneous flow rate] 2.5 times/sec.
[Integrated flow rate] Once/sec.
- ⑤ Full scale setting width: 0001 – 9999 (Decimal point excluded)
- ⑥ Decimal point position setting: Settable to any position
- ⑦ Unit: [Instantaneous flow rate] CCM, LM, m³/h (Freely selectable)
[Integrated flow rate] CC, L, m³
(Locked to the above units, replaced by the user)

- Power output

- ① Output voltage: $\pm 15.0 \text{ V} \pm 5\%$
- ② Output current: $\pm 300 \text{ mA}$
- ③ Ripple: 120 mVp-p (at 100 VAC, 50/60 Hz input)
- ④ Temperature fluctuation: 150 mV (0 – 50°C)

- Power input

- ① Voltage: Single phase, 85 – 264 VAC
- ② Frequency: 48 – 440 Hz
- ③ Power consumption: Approx. 25 W

- Operating environment: 0 – 50°C, 45 – 85% RH (No condensation)

- Others

- ① Flow rate setting: Settable on CR-400 or external equipment.
Switchover between CR-400 and external equipment possible from external equipment also.
- ② Valve forced open/close operation:
Operable on CR-400 and external equipment.
- ③ Event output: Two selected from the following:
Instantaneous flow rate (upper limit, lower limit, upper/lower limit) / integrated flow rate reach
Open collector output (max. rating 50 V/50 mA)
- ④ RS-485 communication: 2 (3)-wire, half duplex, 9600 bps fixed
- ⑤ Data backup: Memory of panel set values, parameter values, integrated flow rate (every minute)

- External dimensions: 73 (W) × 73 (H) × 119.5 (D) mm

- Weight: Approx. 400 g

Connector pin assignment

① CN1 (D-sub half pitch 20-pin/female) : External equipment connection

1	MF flow rate signal output	10	Valve forced open/close control signal common
2	MF flow rate signal output common	11,13	RS-485(TR+)
3	MFC flow rate setting signal input	12,14	RS-485(TR-)
4	MFC flow rate setting signal input common	15,16	RS-485(GND)
5	Valve forced open control signal	17	Event output 1
6	Valve forced close control signal	18	Event output 2
7	Valve forced open control signal input	19	Event output common
8	Valve forced close control signal input	20	HOST/TERM switching signal common
9	HOST/TERM switching signal	Shell	Frame ground

② CN2 (D-sub 9-pin/female) : Mass flow meter/controller connection

1	Valve forced open/close signal
2	MF flow rate signal
3	Power supply +15V DC
4	Power supply common
5	Power supply -15V DC
6	MFC flow rate setting signal
7	MF flow rate signal common
8	MFC flow rate setting signal common
9	N.C.
Shell	Frame ground

 **CAUTION**

- The use of the product in a state exceeding the specifications may cause the product to fail. Consequently, it may cause serious problems to the equipment or machinery incorporating the product or serious accidents.

2. Installation

2.1 Upon receipt of the product

When you have received the product, carefully check the appearance of the packing to make sure it is free of damage or breakage. If a problem is found in the packed condition, have the carrier confirm the situation and at the same time, please contact our sales office or the dealer.

2.2 Installation place

The product may be installed in any posture, but the installation place must be free of dust and water to prevent insulation failure due to condensation.

Where a rise in temperature in the installation place due to equipment installed nearby is expected, install a cooling fan to ventilate the place and provide other necessary measures.

Do not install the product in a place that is subjected to vibrations constantly as it may cause contact failure of the cable connections.

 **CAUTION**

- Never install the product in a wet place.
Hazard of electric shock.
- Do not install the product in a place where ambient temperature rises very high.
Temperature of the internal circuit will rise to cause the circuit to be damaged.
- The installation of the product in a place that is subjected to vibrations constantly may cause contact failure of the cable connections.



2.3 Installation

Install the CR-400 on a panel that has been prepared in accordance with the following drawing.

When installing the CR-400, insert an included washer(s) between the body of the CR-400 and the mounting fixture according to the thickness of the panel so that the CR-400 will not be subjected to excessive stress.

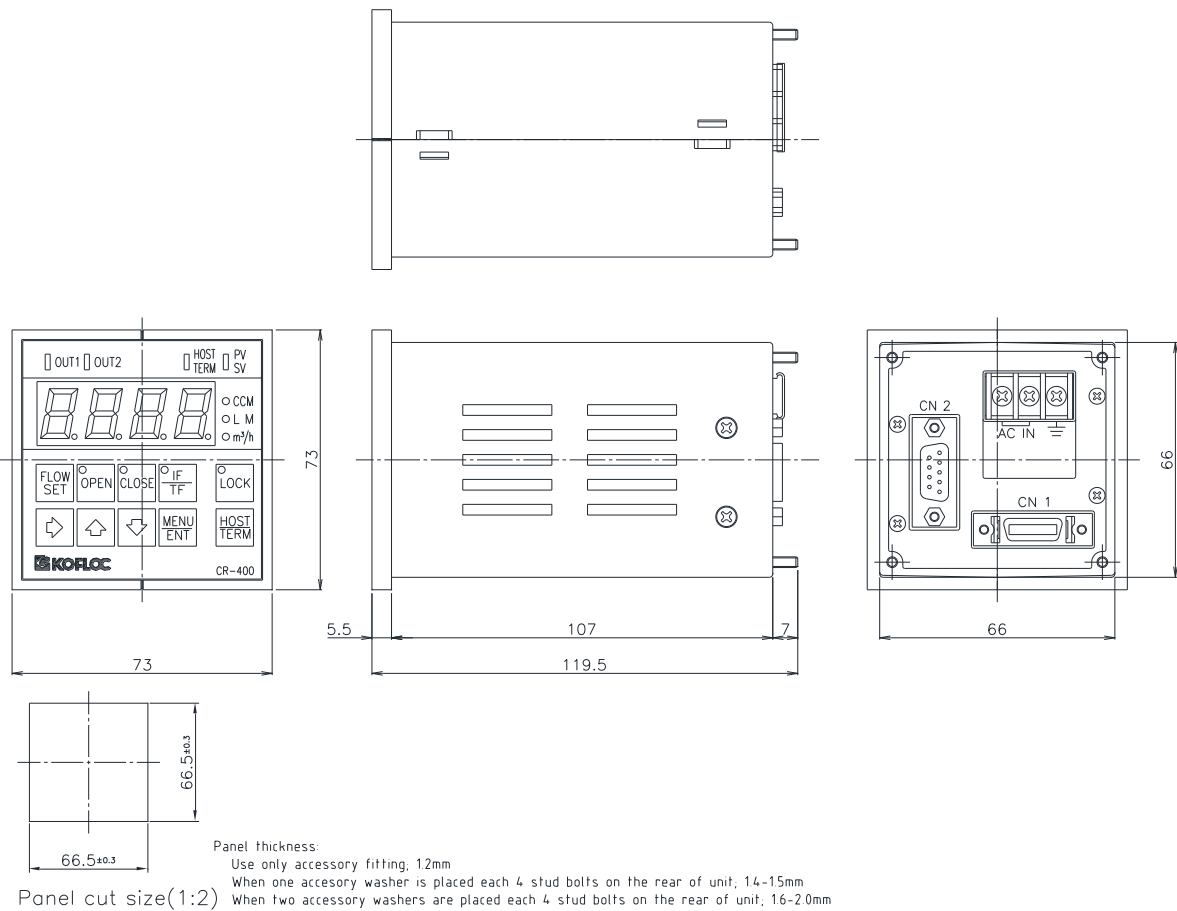

3. Wiring

3.1 Wiring to the mass flow meter/controller

Obtain a dedicated cable suitable for the CR-400 and a mass flow meter or controller to use and connect it to the CN2 connector. To prevent disconnection of the connector, tighten the fixing screw on the cable side.

3.2 Wiring to external equipment

Connect a cable suitable for the CR-400 and external equipment to use to the CN1 connector. To prevent disconnection of the connector, make sure that the quick lock has been applied.

An example of CN1 wiring

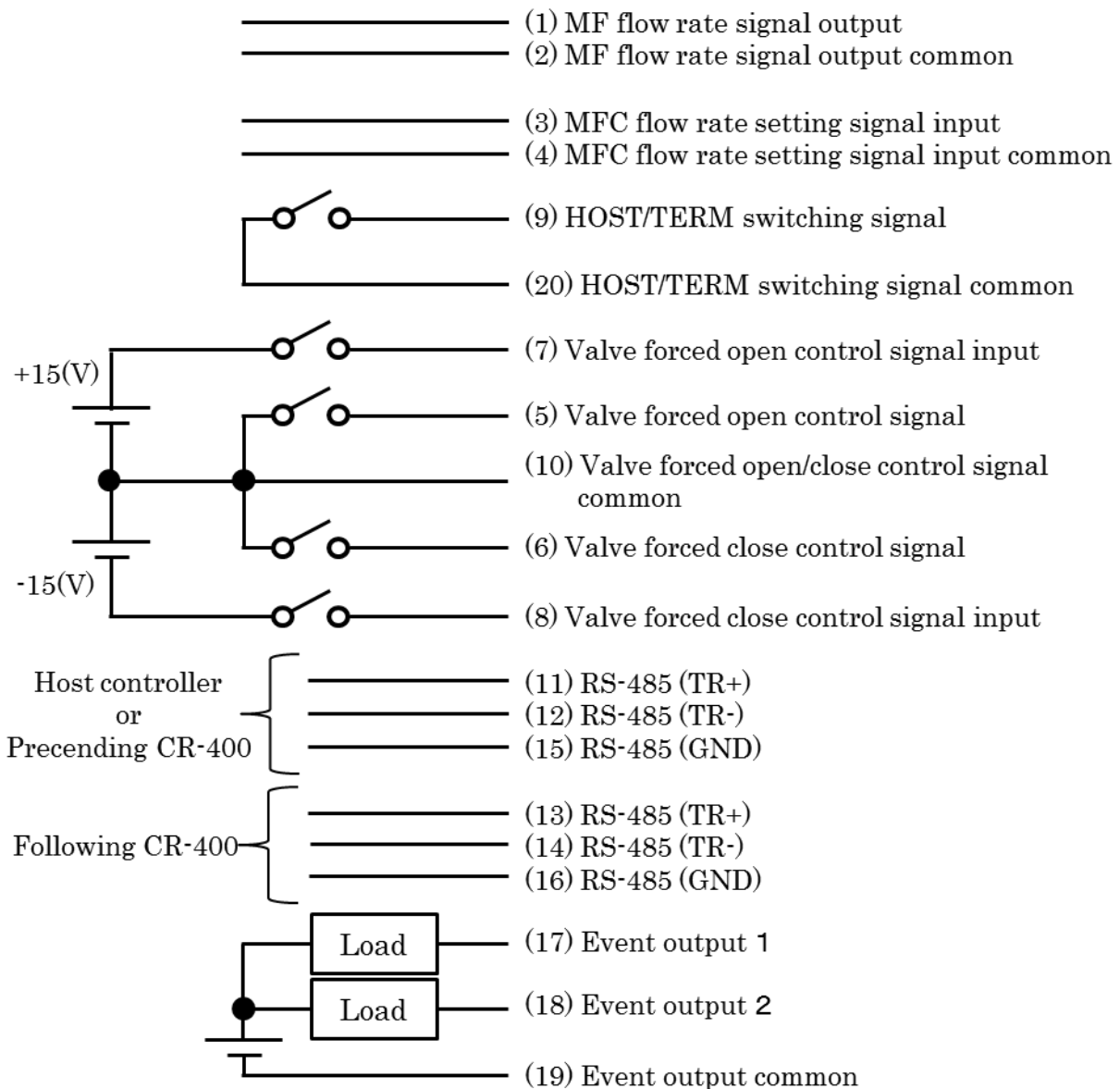

(1) MF flow rate signal output, Pin 1 - Pin 2 [common]

A flow rate signal is output from the mass flow meter/controller.

It may be used for such purpose as monitoring by external equipment.

(2) MFC flow rate setting signal input, Pin 3 – Pin 4 [common]

Input this signal to set a flow rate from external equipment.

To enable this input, the CR-400 must be set to the TERM mode.

(3) HOST/TERM switching signal, Pin 9 – Pin 20 [common]

When connected (shorted), the CR-400 is set to the TERM mode. This mode has a priority over setting by operation of key switches on the panel ((5) Switching over the flow rate setting methods on page 15). When open, the modes of HOST and TERM are set according to the setting made by operation of key switches on the panel.

In the HOST mode, the flow rate set on the CR-400 is valid and in the TERM mode, the flow rate input from external equipment is valid.

Modes according to combination of panel setting and external input setting		Panel setting	
		HOST	TERM
External input setting	Open	HOST	TERM
	Connected (shorted)	TERM	TERM

(4) Valve forced open/close control signal, Pins 5, 6, 7, 8 – Pin 10 [common]

With Pin 10 as common, when Pins 5, 6, 7 and 8 are set as follows, valve forced open/close control signals can be output to the mass flow controller.

Pin 5 and Pin 10 connected (shorted)	→	Forced open control
Pin 6 and Pin 10 connected (shorted)	→	Forced close control
+15 VDC input to Pin 7	→	Forced open control
-15 VDC input to Pin 8	→	Forced close control

Note, however, that these operations must not be performed simultaneously.

For the valve forced open/close control, regardless of the HOST/TERM modes, a priority is given to the setting by operation of key switches on the panel ((3)/(4) Setting the valve forced open/close control on page 15) over these operations.

Valves according to combination of panel setting and external input setting		Panel setting		
		Flow control	Forced open control	Forced close control
External input setting	Flow control	Flow control	Forced open control	Forced close control
	Forced open control	Forced open control	Forced open control	Forced close control
	Forced close control	Forced close control	Forced open control	Forced close control

(5) RS-485 communication, Pins 11 – 16

Configure a communication line by daisy chain connection like; host controller such as PC → CR-400 → CR-400 ...

Two pins each are provided for TR+ (Pins 11/13), TR- (Pins 12/14) and GND (Pins 15/16). The final equipment (CR-400) must have the terminator (page 19) enabled.

(6) Event output, Pins 17 and 18 – Pin 19 [common]

When the conditions set to event 1 and event 2 (pages 17 thru 19) have been met, the corresponding outputs are turned on. Be sure that a load circuit is configured within a range that does not exceed the maximum rating (50 V/50 mA).

4. Nomenclature and Description of the Functions

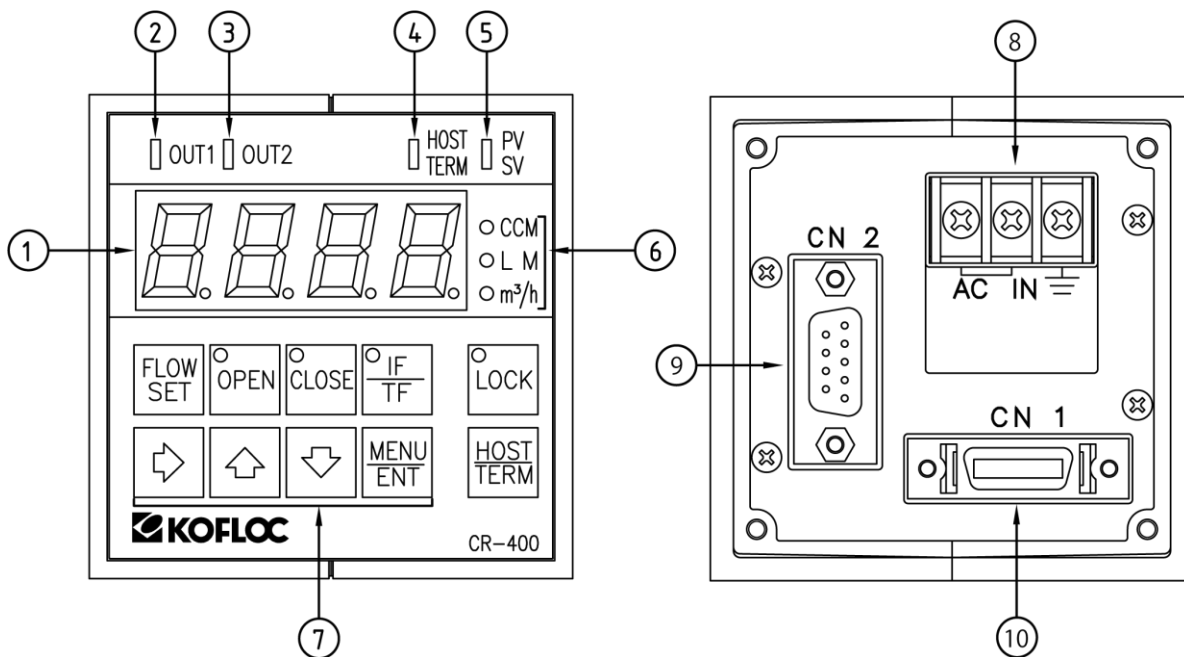

- ① Measured value display (Red 7-segment LED, 4 digits)
Indicates the instantaneous and integrated flow rate values, set values, etc.
- ② Event output 1 indicator (Red LED)
Lights when the event output 1 is on.
- ③ Event output 2 indicator (Red LED)
Lights when the event output 2 is on.
- ④ Flow rate setting method indicator (Green/red LED)
The green LED lights when the flow rate set on the CR-400 is valid (HOST mode) and the red LED lights when the flow rate input from external equipment is valid (TERM mode).
- ⑤ PV/SV indicator (Green/red LED)
The green LED lights when either the instantaneous or integrated flow rate is being indicated on the measured value display. The red LED lights when other value such as a set value is being indicated.
- ⑥ Unit of flow rate indicator (Red LED)
The unit of flow rate of the mass flow meter or controller that is connected (set) lights. When the integrated flow rate is being indicated, read them as “CC / L / m³”.
- ⑦ Key switches
 - Flow set key [FLOW SET]
Used to indicate/set a flow rate value.
 - Valve forced open key [OPEN]
Outputs the valve forced open control signal and the red LED lights.
 - Valve forced close key [CLOSE]
Outputs the valve forced close control signal and the red LED lights.
 - Instantaneous/integrated flow rate switching key [IF/TF]
Switches over the contents of the flow rate indicated (instantaneous/integrated upper 4 digits/integrated lower 4 digits).
When the instantaneous flow rate is being indicated, the green LED lights and when the integrated flow rate is being indicated, the red LED lights.
 - Shift key [→]
Used to move a place to change when changing settings.
 - Up/down keys [↑ / ↓]
Used to change figures, decimal point and unit of flow rate when changing settings.
 - Menu/entry key [MENU/ENT]
Used to show, send and store various settings.
 - Flow rate setting method switching key [HOST/TERM]
The flow rate setting methods can be switched over between the HOST mode and the TERM mode.
 - Lock key [LOCK]
Locks (protects) the operation of setting keys. When locked, the red LED lights.

- ⑧ Power terminal block
A terminal block for connection of the power cable.
- ⑨ Connector for mass flow meter/controller connection
A connector to connect a mass flow meter/controller.
- ⑩ Connector for external equipment connection
A connector to connect external equipment.

5. Operating Procedure

The state of the CR-400 can largely be classified either as a state where the operation of setting key switches is protected (“locked”) and a state where such operation is not protected (“unlocked”). In the locked state, settings cannot be changed at all by operating key switches. To change settings, unprotect and set the CR-400 in the unlocked state.

These two states are switched over with the [LOCK] key. Holding the [LOCK] key pressed for approx. 3 seconds in the locked state (the LED on the [LOCK] key on) unprotects the locked state and sets the unlocked state (the LED of the [LOCK] key off). The unlocked state is changed to the locked state immediately when the [LOCK] key is pressed or, when the auto lock function (page 19) is enabled, when approx. 3 minutes have passed without key operation. Note, however, that either operation is valid only in the flow rate indicating state and in the parameter setting mode, you need to return to the flow rate indicating state once and then perform these operations.

The operations that can be performed in the locked state and the unlocked state will be described below.

[LOCK] key held pressed for approx. 3 sec.

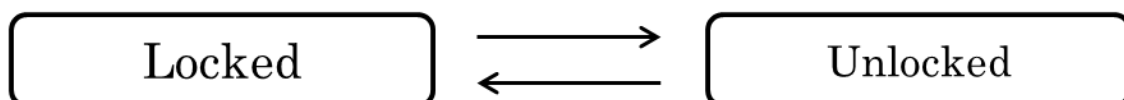

Either [LOCK] key is pressed or approx. 3 minutes have passed without key operation (when auto lock is enabled).

5.1 Locked state

(1) Indicating the flow rate set value

Press the [FLOW SET] key. The flow rate set value will be indicated. After about 2 seconds, the indication will return to the flow rate value.

(2) Indicating the full scale value

Press the [MENU/ENT] key. The full scale set value will be indicated. After about 2 seconds, the indication will return to the flow rate value.

(3) Switching over the indicated flow rate values

Each time the instantaneous/integrated flow rate switching key [IF/TF] is pressed, the indication will change as shown below. Note, however, when the integrated flow rate is 4 digits or less, “integrated flow rate (upper 4 digits)” is skipped.

The flow rate that is being indicated can be identified by a color of the LED on the [IF/TF] key (instantaneous: green, integrated: red) and the presence of the decimal point (no: integrated upper, yes: integrated lower).

The indicated flow rate values can be switched over in any state, regardless of the locked or unlocked state.

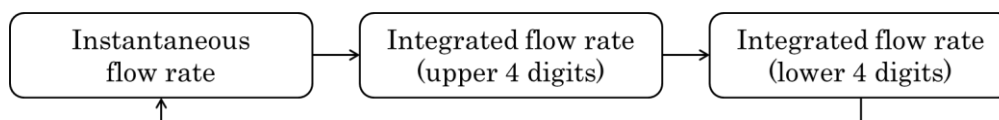

5.2 Unlocked state

(1) Setting a flow rate value

- ① Press the [FLOW SET] key.
- ② The CR-400 will enter the flow rate set value input mode and the highest digit on the measured value display will start flashing.
- ③ Set a desired value by operating the shift key [→] and up/down keys [↑]/[↓].
Use the shift key to move the change place (flashing point).
Use the up/down keys to increase/decrease a value.
- ④ Press the [MENU/ENT] key to store the setting.
 - ※ The settable range is less than the full scale value that has been set.
 - ※ The decimal point position and the unit of flow rate have been fixed to the same position and unit as the full scale value setting.

(2) Setting the full scale and other parameters [Parameter setting mode]

- ① Press the [MENU/ENT] key.
- ② The CR-400 will enter the parameter setting mode and the first parameter name “P-00” will be shown.
- ③ Press the [MENU/ENT] key.
- ④ The present value of P-00 will be indicated and the highest digit will start flashing.

- ⑤ Change the setting by operating the shift key [→] and up/down keys [↑]/[↓].
Use the shift key to move the change place (flashing point).
Use the up/down keys to increase/decrease a value.
To change the decimal point position or the unit of flow rate, move the flashing point to a place to change and specify it with the up key or down key.
- ⑥ Press the [MENU/ENT] key.
- ⑦ The next parameter name “P-10” will be shown.
When the same procedure is repeated to show the parameter names and change settings and the last parameter is completed, the first parameter name “P-00” will be shown again.
When the [MENU/ENT] key is held pressed for approx. 3 seconds, the parameter setting mode will be ended and the display will return to the flow rate indication and the changes made to the settings will be stored.
For the contents of parameters, refer to “Parameter Setting” (page 17).

(3) Setting the valve forced open control

- ① Press the valve forced open key [OPEN].
The LED will light and the valve control signal to the MFC will be set to “forced open.” (The actual outputs to the MFC depend on a combination with external input settings. See page 11.)
- ② To return to the flow control state, press the valve forced open key [OPEN] again.

(4) Setting the valve forced close control

- ① Press the valve forced close key [CLOSE].
The LED will light and the valve control signal to the MFC will be set to “forced close.” (The actual outputs to the MFC depend on a combination with external input settings. See page 11.)
- ② To return to the flow control state, press the valve forced close key [CLOSE] again.

(5) Switching over the flow rate setting methods

Each time the flow rate setting method switching key [HOST/TERM] is pressed, the flow rate setting methods will be switched over. (The actual outputs to the MFC depend on a combination with external input settings. See page 10.)

HOST mode (CR-400) ⇔ TERM mode (External equipment)

In the HOST mode, the flow rate set on the CR-400 is valid and in the TERM mode, the flow rate set on external equipment is valid and they are output to the MFC.

The mode the CR-400 is in at present can be known by a color of the flow rate setting method indicator lamp (green: HOST, red: TERM).

(6) Initializing the integrated flow rate

- ① When the integrated flow rate (upper or lower) is being indicated, hold the instantaneous/integrated flow rate switching key [IF/TF] pressed.
 - ② The measured value display will show “rSEt (RSET)” flashing.
 - ③ When the [IF/TF] key is held pressed for approx. 3 seconds, the integrated flow rate will be initialized.
- ※ When the [IF/TF] key is released before the integrated flow rate is initialized, the indication will return to the integrated flow rate.

A list of major operations

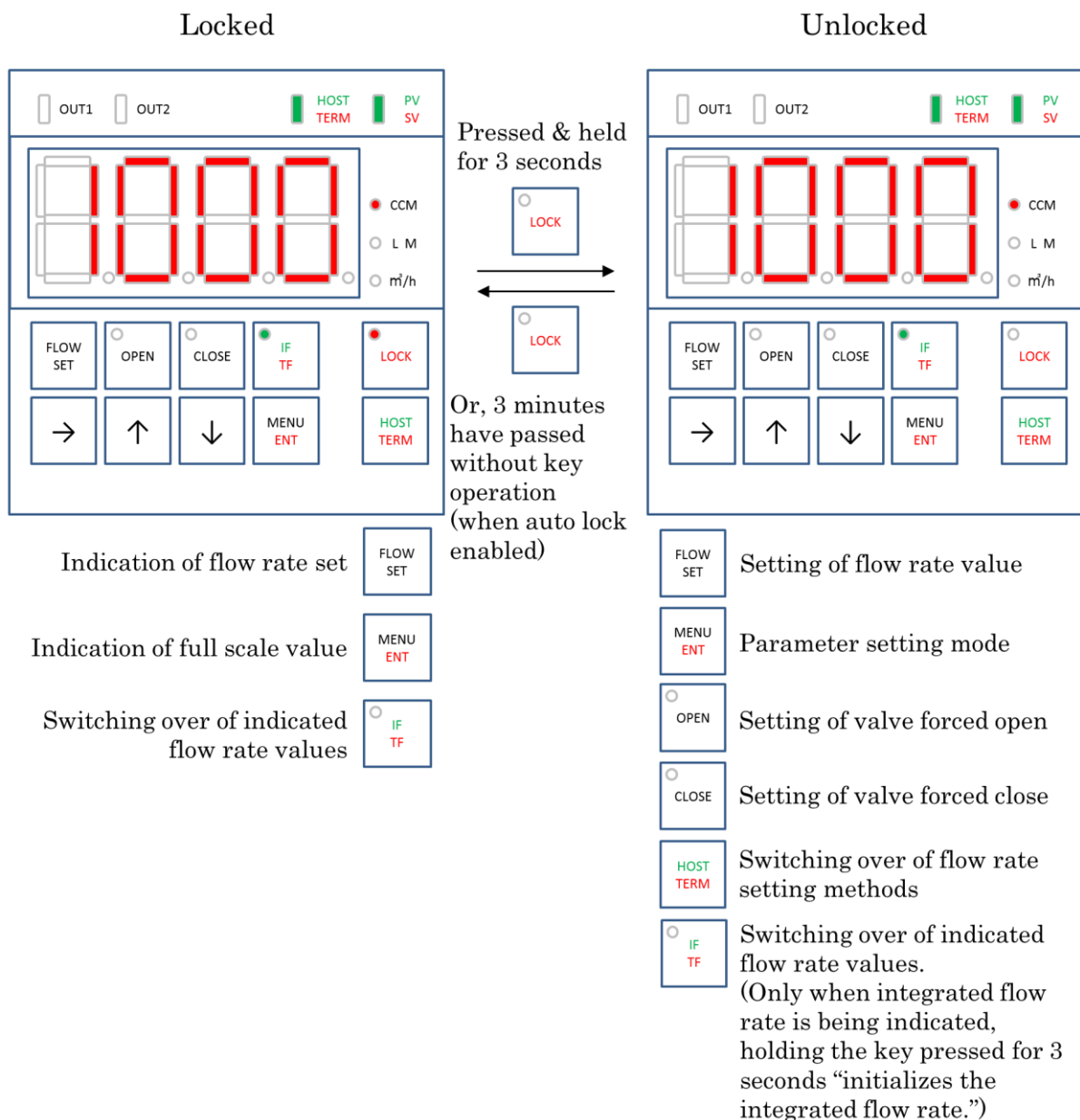

6. Parameter Setting

The CR-400 allows its operation to be customized by changing parameters. Parameters are changed in the parameter setting mode. To go to the parameter setting mode, hold the [LOCK] key pressed for approx. 3 seconds to unprotect and set the CR-400 in the unlocked state. In the unlocked state, press the [MENU/ENT] key to go to the parameter setting mode. For the following operations, see “Setting the full scale and other parameters” (page 14).

The contents of parameters and their setting ranges will be explained below. Note that some parameters are invalidated and not shown depending on the contents of settings of other parameters.

(P-00) Full scale Set a value to indicate when the flow rate signal from the MF is the full scale (5 V input).
[Value] Range: 0001 – 9999 (Must be above “flow rate set value”)
[Decimal point position] No decimal place, 1 decimal place, 2 decimal places, 3 decimal places
[Unit of flow rate] CCM, LM, m ³ /h ※ When this parameter is changed, the integrated flow rate value will be reset automatically.

(P-10) Event output 1 Event selection Select an event condition to be set to Event output 1.
(0) None: Not used (1) Instantaneous flow rate upper limit: Instantaneous flow rate above “instantaneous flow rate upper limit preset (P-1U)” (2) Instantaneous flow rate lower limit: Instantaneous flow rate below “instantaneous flow rate lower limit preset (P-1L)” (3) Instantaneous flow rate upper/lower limit: Instantaneous flow rate above “instantaneous flow rate upper limit preset (P-1U)” or below “instantaneous flow rate lower limit preset (P-1L)” (4) Integrated flow rate reach: Integrated flow rate above “integrated flow rate reach preset (P-1T)”

(P-1U) Event output 1 Instantaneous flow rate upper limit preset Settable only when “instantaneous flow rate upper limit” or “instantaneous flow rate upper/lower limit” has been selected in (P-10). Range: 0000 – 9999 ※ The decimal point position and the unit of flow rate are the same as “Full scale.”
--

(P-1L) Event output 1 Instantaneous flow rate lower limit preset Settable only when “instantaneous flow rate lower limit” or “instantaneous flow rate upper/lower limit” has been selected in (P-10). Range: 0000 – 9999 ※ The decimal point position and the unit of flow rate are the same as “Full scale.”
--

(P-1I) Event output 1 Instantaneous flow rate initial judgment prohibit time
Set a time before starting judgment of events after the CR-400 was powered on.

Settable only when “instantaneous flow rate upper limit,” “instantaneous flow rate lower limit” or “instantaneous flow rate upper/lower limit” has been selected in (P-10).
Range: 00 – 99 (seconds)

(P-1D) Event output 1 Instantaneous flow rate judgment delay time

When an event judgment condition has been met or not, outputs will be changed if such state continues for the time set here.

Settable only when “instantaneous flow rate upper limit,” “instantaneous flow rate lower limit” or “instantaneous flow rate upper/lower limit” has been selected in (P-10).
Range: 00 – 99 (seconds)

(P-1T) Event output 1 Integrated flow rate reach preset

Settable only when “integrated flow rate reach” has been selected in (P-10).

Range: 00000000 – 99999999

- ※ Setting is indicated from upper 4 digits and as the digit to change is moved, the indication changes between the upper and lower digits automatically. Identify the upper and lower digits by the presence of the decimal point (no: upper, yes: lower).
- ※ The unit of flow rate and the decimal point position of lower 4 digits are the same as “Full scale.”
Replace the units of flow rate as CCM → CC, LM → L and m³/h → m³.

(P-20) Event output 2 Event selection

Select an event condition to be set to Event output 2.

- (0) None: Not used
- (1) Instantaneous flow rate upper limit: Instantaneous flow rate above “instantaneous flow rate upper limit preset (P-2U)”
- (2) Instantaneous flow rate lower limit: Instantaneous flow rate below “instantaneous flow rate lower limit preset (P-2L)”
- (3) Instantaneous flow rate upper/lower limit: Instantaneous flow rate above “instantaneous flow rate upper limit preset (P-2U)” or below “instantaneous flow rate lower limit preset (P-2L)”
- (4) Integrated flow rate reach: Integrated flow rate above “integrated flow rate reach preset (P-2T)”

(P-2U) Event output 2 Instantaneous flow rate upper limit preset

Settable only when “instantaneous flow rate upper limit” or “instantaneous flow rate upper/lower limit” has been selected in (P-20).

Range: 0000 – 9999

- ※ The decimal point position and the unit of flow rate are the same as “Full scale.”

(P-2L) Event output 2 Instantaneous flow rate lower limit preset

Settable only when “instantaneous flow rate lower limit” or “instantaneous flow rate upper/lower limit” has been selected in (P-20).

Range: 0000 – 9999

- ※ The decimal point position and the unit of flow rate are the same as “Full scale.”

(P-2I) Event output 2 Instantaneous flow rate initial judgment prohibit time

Set a time before starting judgment of events after the CR-400 was powered on.

Settable only when “instantaneous flow rate upper limit,” “instantaneous flow rate lower limit” or “instantaneous flow rate upper/lower limit” has been selected in (P-20).
Range: 00 – 99 (seconds)

(P-2D) Event output 2 Instantaneous flow rate judgment delay time
When an event judgment condition has been met or not, outputs will be changed if such state continues for the time set here.

Settable only when “instantaneous flow rate upper limit,” “instantaneous flow rate lower limit” or “instantaneous flow rate upper/lower limit” has been selected in (P-20).
Range: 00 – 99 (seconds)

(P-2T) Event output 2 Integrated flow rate reach preset

Settable only when “integrated flow rate reach” has been selected in (P-20).
Range: 00000000 – 99999999

- ※ Setting is indicated from upper 4 digits and as the digit to change is moved, the indication changes between the upper and lower digits automatically.
Identify the upper and lower digits by the presence of the decimal point (no: upper, yes: lower).
- ※ The unit of flow rate and the decimal point position of lower 4 digits are the same as “Full scale.”
Replace the units of flow rate as CCM → CC, LM → L and m³/h → m³.

(P-30) Low cut function

Specify a level at which the instantaneous flow rate is deemed “0” by a percentage (%) of the “full scale.”

Note that when this parameter is set to “0”, this function is disabled and negative values are indicated also.

Range: 0 (Function disabled) 1 – 9 (%)

(P-40) Forced open/close signals

Set forced open/close signals according to the specifications of the mass flow controller to connect.

- (0) Forced open [+15 V], forced close [-15 V]
- (1) Forced open [-15 V], forced close [+15 V]

(P-50) Auto lock function

Set the auto lock function to be enabled/disabled.

When this is enabled, if no key is operated for approx. 3 minutes in the unlocked or unprotected state (excluding the parameter setting mode), the key lock will automatically be applied.

- (0): Disabled
- (1): Enabled

(P-60) RS-485 communication/equipment ID

Of the commands received, response will be made only when the destination ID matches this setting. Set unique IDs when connecting several CR-400 units.

Range: 001 – 127

(P-70) RS-485 communication/terminator

Set the terminator to be enabled or disabled.

Enable the terminator of only the last equipment in the daisy chain connection.

- (0): Disabled
- (1): Enabled

7. RS-485 Communication

7.1 Basic specifications

Sync/speed	Start-stop / 9600 bps
Frame structure	Start: 1 bit Data length: 8 bits Stop: 1 bit Parity: No
Transmission system	2 (3)-wire half-duplex

- ※ Starting with a host controller such as a PC, connect CR-400 units by daisy chain connection.
- ※ Set parameters so that each piece of equipment is given a unique ID and the terminator of only the last equipment is enabled. (Page 19).

7.2 Commands and responses

An address has been assigned to each of parameters handled by the CR-400. The command system is simple, read or write only to such addresses.

(1) Read command [Host controller → CR-400]

STX	Equipment ID			R	Address			
02H	○	○	○	52H	△	△	△	△

ETX	Check sum		CR	LF
03H	□	□	0DH	0AH

(2) Read response [CR-400 → host controller]

STX	Equipment ID			R	Address				Exit code	
02H	○	○	○	52H	△	△	△	△	×	×

Sign	Digits	Data			ETX	Check sum		CR	LF
◎	▽	△	...	△	03H	□	□	0DH	0AH

(3) Write command [Host controller → CR-400]

STX	Equipment ID			W	Address			
02H	○	○	○	57H	△	△	△	△

Sign	Digits	Data			ETX	Check sum		CR	LF
◎	▽	△	...	△	03H	□	□	0DH	0AH

(2) Write response [CR-400 → host controller]

STX	Equipment ID			W	Address				Exit code	
02H	○	○	○	57H	△	△	△	△	×	×

ETX	Check sum		CR	LF
03H	□	□	0DH	0AH

STX	02H (fixed)
Equipment ID	Each digit of destination (3 digits) converted to ASCII code
Type	“R” (52H) or “W” (57H)
Address	Each digit of address (4 digits) to read/write converted to ASCII code
Exit code	“00” (30H/30H) Normal response “40” (34H/30H) Communication inaccessible area specified “41” (34H/31H) Invalid item address specified “42” (34H/32H) Undefined command specified
Sign	Sign of data ‘+’ (2BH) or ‘-’ (2DH)
Digits	Number of data digits converted to ASCII code
Data	Each digit of data (number of digits specified by “Digits”) converted to ASCII code
ETX	03H (fixed)
Check sum	Added every 1 byte from STX to ETX Each digit of lower 1 byte (HEX 2 digits) converted to ASCII code
CR	0DH (fixed)
LF	0AH (fixed)

7.3 Description of the addresses

The addresses and their description, number of digits, attributes and ranges will be explained below.

You can access parameter values (values operated in the parameter setting mode), panel set values (values operated in modes other than the parameter setting mode such as flow rate setting) and state value (value indicating the present state) via read/write to each address.

Note, however, that you must use the specified number of digits to access each address. The addresses indicated by the attribute “R” means read only (read command) and write (write command) is not accepted.

Parameter values				
Address	Description	Digits	Attribute	Range
0000	(P-00) Full scale [Value]	4	R/W	0001 - 9999 (But, above “flow rate set value”)
0001	(P-00) Full scale [Decimal point position]	1	R/W	No decimal place (0), 1 decimal place (1), 2 decimal places (2), 3 decimal places (3)
0002	(P-00) Full scale [Unit of flow rate]	1	R/W	CCM (0), LM (1), m ³ /h (2)
0010	(P-10) Event output 1 Event selection	1	R/W	No (0), instantaneous flow rate upper limit (1), in- stantaneous flow rate lower limit (2), instantaneous flow rate upper/lower limit (3), integrated flow rate reach (4)
0011	(P-1U) Event output 1 Instantaneous flow rate upper limit preset	4	R/W	0000 - 9999
0012	(P-1L) Event output 1 Instantaneous flow rate lower limit preset	4	R/W	0000 - 9999
0013	(P-1I) Event output 1 Instantaneous flow rate initial judgment prohibit time	2	R/W	00 - 99 (sec)
0014	(P-1D) Event output 1 Instantaneous flow rate judgment delay time	2	R/W	00 - 99 (sec)
0015	(P-1T) Event output 1 Integrated flow rate reach preset	8	R/W	00000000 - 99999999
0020	(P-20) Event output 2 Event selection setting	1	R/W	No (0), instantaneous flow rate upper limit (1), in- stantaneous flow rate lower limit (2), instantaneous flow rate upper/lower limit (3), integrated flow rate reach (4)
0021	(P-2U) Event output 2 Instantaneous flow rate upper limit preset	4	R/W	0000 - 9999
0022	(P-2L) Event output 2 Instantaneous flow rate lower limit preset	4	R/W	0000 - 9999
0023	(P-2I) Event output 2 Instantaneous flow rate initial judgment prohibit time	2	R/W	00 - 99 (sec)

0024	(P-2D) Event output 2 Instantaneous flow rate judgment delay time	2	R/W	00 - 99 (sec)
0025	(P-2T) Event output 2 Integrated flow rate reach preset	8	R/W	00000000 - 99999999
0030	(P-3O) Low cut function	1	R/W	0 (Function disabled), 1-9 (%)
0040	(P-4O) Forced open/close signals	1	R/W	Full open [+15V], full close [-15V] (0), Full open [-15V], full close (+15V) (1)
0050	(P-5O) Auto lock function	1	R/W	Disabled (0), enabled (1)

Panel set values				
Address	Description	Digits	Attribute	Range
0100	Valve setting	1	R/W	Flow control (0), forced open (1), forced close (2)
0200	Flow rate setting method	1	R/W	HOST · CR-400 (0), TERM · External equipment (1)
0300	Flow rate set value	4	R/W	0000 ~ 9999 (But, below "full scale [value]")

State values				
Address	Description	Digits	Attribute	Range
1000	Instantaneous flow rate value	4	R	- 9999
2000	Integrated flow rate value	8	R/W	00000000 - 99999999 ("W": "00000000" only)
3000	Event output 1	1	R	Event not triggered (0), event triggered (1)
4000	Event output 2	1	R	Event not triggered (0), event triggered (1)
5000	Valve	1	R	Flow rate control (0), forced open (1), forced close (2)
6000	Flow rate setting method	1	R	HOST · CR-400 (0), TERM · External equipment (1)

7.4 An example of communication

(Command) “Instantaneous flow rate value (address: 1000)” to be acquired from the CR-400 whose equipment ID has been set to “123”

STX	Equipment ID			R	Address			
	1	2	3		1	0	0	0
02H	31H	32H	33H	52H	31H	30H	30H	30H

ETX	Check sum		CR	LF
	A	E		
03H	41H	45H	0DH	0AH

※ Check sum calculation

$$\begin{aligned}
 &02H + 31H + 32H + 33H + 52H \\
 &+ 31H + 30H + 30H + 30H + 03H = 1AEH
 \end{aligned}$$

(Response) “Instantaneous flow rate” is “1234”

STX	Equipment ID			R	Address				Exit code	
	1	2	3		1	0	0	0	0	0
02H	31H	32H	33H	52H	31H	30H	30H	30H	30H	30H

Sign	Digits	Data				ETX	Check sum		CR	LF
+	4	1	2	3	4		3	7		
2BH	34H	31H	32H	33H	34H	03H	33H	37H	0DH	0AH



WARNING

- Use dedicated cables. Hazard of rupture.



If an improper cable is connected, the product and the mass flow meter/controller may be damaged. Note that if the shape of connectors is the same and the number of pins is the same, the pin layout may be different depending on types of mass flow meters/controllers.

If you want to connect a cable you purchased to a mass flow meter/controller that is not compatible with such cable, please contact our sales office or the dealer.

8. Failure

8.1 If failure is suspected

If you suspect the product failed, in order to prevent short circuit accidents, never try to check output voltages with the connector pins of the product, but use the check terminals or other safe parts of the connected equipment. If the product has actually failed, please contact our sales office or the dealer.



DANGER

- Never overhaul the product. It is a very dangerous practice as you may touch internal parts to suffer electric shock.



8.2 Warranty

① Warranty period

The warranty period is one (1) year after shipment from KOFLOC.

② Scope of warranty

If the KOFLOC product fails during the warranty period due to a cause attributable to KOFLOC, KOFLOC will, at its option and expense, provide a replacement product or repair the failed product at the KOFLOC factory.

This warranty, however, shall not cover damages due to a cause not attributable to KOFLOC, opportunity loss, lost profit, secondary disaster and accident compensation suffered by the customer and damage to other equipment and any other compensation due to failure of the KOFLOC product.

③ Out of warranty

The warranty shall not apply to the following failures even if they occur during the warranty period:

- a) Failure due to misuse or improper repair or modification. (Failure resulting from use under conditions different from the manufacturing specifications is included.)
- b) Failure due to dropping of the product after purchase.
- c) Failure due to fire, earthquake, flood, lightning or other natural disaster, or riot, war or the like.
- d) Failure due to intrusion of foreign matter from piping.
- e) Failure caused by a problem specific to a combination with other incorporated equipment.
- f) Other failures which are considered not attributable to KOFLOC.

Please be aware that the warranty shall not cover opportunity loss suffered by the customer or end user or damage to other equipment or any other damages due to failure of the KOFLOC product.

KOFLOC Corp.

URL : <http://www.kofloc.co.jp>